

Jiangsu Weixiang Tool Manufacturing Co.,Ltd.



**Professional cutting tools and
router bits**

ENTERPRISE INTRODUCE

企业简介

JIANGSU WEIXIANG TOOL MANUFACTURING CO., LTD. IS A COMPREHENSIVE TOOL MANUFACTURER AND DISTRIBUTOR INTEGRATING PRODUCTION, SALES AND R & D. THE COMPANY HAS 30 YEARS OF EXPERIENCE IN THE PRODUCTION AND SALES OF CEMENTED CARBIDE CUTTING TOOLS, HIGH-QUALITY REPUTATION, EXCELLENT PRODUCT QUALITY AND HIGH COST PERFORMANCE ARE THE FUNDAMENTAL REASONS FOR THE COMPANY'S SURVIVAL AND DEVELOPMENT. THE COMPANY IS LOCATED IN DAGANG ECONOMIC DEVELOPMENT ZONE, A BOOMING NATIONAL ECONOMIC DEVELOPMENT ZONE BESIDE THE BEAUTIFUL YANGTZE RIVER. IT IS ONLY 5 KILOMETERS AWAY FROM THE ENTRANCE OF ZHENTAI EXPRESSWAY. IT HAS MORE THAN 10 IMPORTED FIVE AXIS CNC MACHINING CENTERS SUCH AS WALTER AND ANCA, AND USES ADVANCED GERMAN ZOLLER TESTING EQUIPMENT. THOUSANDS OF PRODUCTS AND SPECIFICATIONS ARE IN STOCK TO ENSURE THAT CUSTOMERS ORDER WHAT THEY NEED. DOMESTIC SALES OUTLETS IN JINAN, WUXI AND KUNSHAN, DONGGUAN, CHENGDU AND OTHER PLACES. AT THE SAME TIME THE COMPANY HAS 10 YEARS OF FOREIGN TRADE EXPERIENCE, PRODUCTS ARE EXPORTED TO EUROPE AND THE UNITED STATES, SOUTHEAST ASIA AND OTHER COUNTRIES. THE COMPANY CONTINUES TO SELECT THE EXISTING COMPLEX CUTTING TOOL PRODUCTION LINE, INCREASE PRODUCT VARIETIES, SPECIFICATIONS, IMPROVE PRODUCT GRADE, AND MAKE OUR EFFORTS FOR THE LOCALIZATION OF FIRST-CLASS CUTTING TOOLS. IN THE COMPETITIVE ENVIRONMENT FULL OF FOREIGN SUPPLIERS, ONLY SUCH SERVICES CAN ACHIEVE SUSTAINABLE DEVELOPMENT. THE COMPANY HAS PASSED THE ISO9001 QUALITY MANAGEMENT SYSTEM TO PROVIDE MORE SCIENTIFIC AND STANDARDIZED MANAGEMENT ASSURANCE FOR THE PRODUCT QUALITY OF THE COMPANY. MAIN PRODUCTS: END MILLING CUTTER, BALL END MILLING CUTTER, ROUND NOSE CUTTER, DEEP GROOVE CUTTER FOR INTEGRAL ALLOY DIE STEEL; SPECIAL MILLING CUTTER FOR ALUMINUM ALLOY, SPECIAL CUTTER FOR STAINLESS STEEL; DRILLING CUTTER (TWIST DRILL, CENTERING DRILL, CENTER DRILL), ETC., AND UNDERTAKE ALL KINDS OF NON-STANDARD CUTTER CUSTOMIZATION. THE COMPANY GUARANTEES TO GUARANTEE THE QUALITY WITHIN THE SHORTEST DELIVERY TIME, AND REFUND THE UNSATISFIED RETURNS. WELCOME TO THE PROCESSING OF INCOMING MATERIALS AND SAMPLES, A LARGE AMOUNT OF DISCOUNT.

江苏维香工具制造有限公司是一家集生产、销售、研发于一体的综合性刀具制造销售商。公司拥有30年的整体硬质合金刀具生产和销售经验,优质的信誉,过硬的产品质量和高性价比是公司生存和发展的根本原因。公司地处美丽的长江边的蓬勃发展的国家级经济开发区一大港经济开发区,邻镇泰高速公路入口仅5公里,拥有瓦尔特(WALTER)和安卡(ANCA)等全进口五轴数控加工中心十余台,使用先进德国ZOLLER检测设备。库存上千种产品和规格,以保证客户订购所需。国内销售门市在济南,无锡和昆山,东莞,成都等地。同时公司已有10年外贸经验,产品远销欧美,东南亚等国家。公司不断对现有的复杂刀具生产线进行改造,增加产品品种、规格、提高产品档次,为一流刀具的国产化做出我们的努力。在充斥着国外供应商的竞争环境中,唯有这样的服务才达到可持续发展的目标。公司已通过ISO9001质量管理体系,为公司的产品质量提供更加科学、规范的管理保证。主要产品:整体合金模具钢用立铣刀、球头铣刀、圆鼻刀、深沟刀;铝合金专用铣刀、不锈钢专用刀;钻削刀具(麻花钻、定心钻、中心钻)等,并承接各种非标刀具定做。公司保证在最短交货期内,保证质量,不满意退货退款。欢迎来料、来样加工,量大优惠。



CONSULTING ORDERS
咨询下单

SERVICE

专业 负责 耐心 细致



AFTER SALE
售后服务

PROFESSIONAL

质量保证 尺寸精准



CUSTOM PRODUCTION
定制生产

NO WORRIES

提供售后解决方案

WEIXTOOLSTORE

先进的数控设备
严谨的生产制造

**COMPREHENSIVE CARBIDE TOOL
MANUFACTURER WITH PRODUCTION**

综合性刀具制造销售商





















目录

Solid Carbide CNC Router Bit

硬质合金CNC铣刀

	1006	Solid Carbide One Flute End Mill 亚克力单刃刀	01
	1015	Solid Carbide One Flute End Mill For Aluminum 单刃铝用刀	03
	1047	Solid Carbide One Flute Downcut End Mill 亚克力单刃刀下切	04
	1011	Solid Carbide Two Flutes Spiral End Mill 二刃木工螺旋铣刀	05
	3098	Solid Carbide One Flute End Mill For Aluminum Profile 单刃铝型材仿型铣刀	07
	1119	Solid Carbide Two Flutes Square End Mill For Aluminum Profile 二刃铝型材仿型铣刀	07
	1192	Solid Carbide Step Drill Bit For Aluminum Profile 铝型材台阶钻	08
	1013	Solid Carbide Three Flutes Spiral End Mill 三刃木工螺旋铣刀	09
	1017	Solid Carbide Two Flutes Ball Nose End Mill 二刃木工球头铣刀	10
	1028	Solid Carbide Two Flutes Tapered Ball Nose End Mill 二刃木工锥度球头铣刀	12
	1036	Solid Carbide Two Flutes Compression Up&Downcut End Mill 二刃木工复合铣刀	13
	1038	Solid Carbide Three Flutes Compression Up&Downcut End Mill 三刃木工复合铣刀	14
	1008	Solid Carbide Corn End Mill 玉米铣刀	15
	1075	Solid Carbide Three Flutes Roughing and Finishing End Mill 三刃半波刃粗皮铣刀	16
	1030	Solid Carbide Three Flutes Roughing End Mill 三刃木工粗皮铣刀	16
	1020	Solid Carbide Two Flutes Straight Slot End Mill 二刃直槽铣刀	18
	1022	Solid Carbide Flat Bottom Engraving Bit 平底尖刀	19
	1024	Solid Carbide Three Edge Engraving Bit 三棱尖刀	20
	1079	Solid Carbide Ball Nose Straight Slot Engraving Bit 二刃直槽球头尖刀	21
	1301	Solid Carbide Step Endless Engraving Bit 无边刻字刀	21
	1302	Solid Carbide Led Neon Signmaking End Mill 霓虹灯亚克力灯管专用铣刀	22
	1081	TCT Two Flutes Straight Bit TCT二刃木工直刀	23
	1080	TCT Three Flutes Straight Bit With Teeth TCT三刃开料刀	25
	1087	TCT Two Flutes Spiral Bit TCT二刃木工螺旋木工刀	26
	1102	TCT Three Flutes Spiral Bit TCT三刃木工螺旋木工刀	27
	1103	TCT Two Flutes Compression Bit With Teeth TCT二刃复合刀带横槽	27











CONTENTS

		1104 TCT Round Bottom Bit TCT圆底刀	28
		1077 TCT Tenon Mortise Bit TCT榫槽刀	28
PCB Drill Bit & End Mill			
PCB钻头与铣刀		1014 PCB Drill Bit PCB钻头	29
		1012 PCB End Mill PCB铣刀	31
Carbide Tipped Boring Drill Bit			
合金木工钻头		1068 Carbide Tipped Dowel Boring Bit 经济款合金排钻	33
		1066 Carbide Tipped High Performance Dowel Boring Bit 高性能合金排钻	34
		1067 Carbide Tipped Extended Dowel Boring Bit 经济款加长型合金排钻	35
		1107 Carbide Tipped Through-hole Boring Bit 经济款通孔钻	36
		1060 Carbide Tipped Centre Boring Bit 合金中心钻	37
		1109 Carbide Tipped Type B Dowel Boring Bit 合金皇冠钻	39
		1074 Carbide Tipped High Performance Centre Boring Bit 高性能中心钻	40
		1108 Carbide Tipped High Performance Through-hole Boring Bit 高性能合金通孔钻	41
		1111 TCT Through Hole Boring Bit 刃部合金通孔钻	42
		1112 TCT Type B Dowel Boring Bit 刃部合金皇冠钻	43
Carbide Tipped Router Bit			
合金花型刀		1025 Carbide Tipped Cleaning Bottom Bit 木工清底刀	45
		1121 Carbide Tipped T-Slot Surfacing Bit 木工T型刀	45
		1033 Carbide Tipped V-Groove Bit 木工V槽刀	46
		1027 Carbide Tipped Round Bottom Bit 木工圆底刀	48
		1005 Carbide Tipped Roundover Pointed Bit 木工尖嘴刀	48
		1004 Carbide Tipped V-Groove Bit For Folding ACM Panels 木工铝塑板专用V型刀	49
		1303 Carbide Tipped Bowl & Tray Bit 双弧圆底刀	49
		1218 Rought Bit 花型刀合集	50
		1239 Rought Bit Set 花型刀套装	52

目录











HSS CNC Router Bit & Drill Bit

高速钢CNC铣刀与钻头

	3099	HSS One Flute End Mill For Aluminum Profile 高速钢单刃铝型材仿型铣刀	53
		Product Information 全磨钻产品信息	55
	3035	HSS Twist Drill Bit 高速钢全磨钻	56
		HSS Twist Drill Bit Set 高速钢全磨钻套装	56
	30791	HSS One Flute Chamfer Countersink Drill Bit 高速钢单刃倒角钻	58
	30792	HSS Three Flutes Chamfer Countersink Drill Bit 高速钢三刃倒角钻	58
	3050	HSS Straight Step Drill Bit 高速钢直槽宝塔钻	59
	3051	HSS Spiral Step Drill Bit 高速钢螺旋槽宝塔钻	59
	3090	HSS Tenon Mortise Bit 高速钢榫眼刀	60
	3107	HSS Flume End Mill 高速钢水槽铣刀	60
	3091	HSS External Drill Bit 高速钢外牙钻	60
	3182	HSS Salad Drill Bit 高速钢沙拉钻	61
	3010	HSS Square Hole Drill Bit 高速钢方孔钻	61

Diamond & TCT Circular Saw Blades

金刚石&合金锯片

	601	Diamond Circular Saw Blade 金刚石锯片	63
	602	TCT Circular Saw Blade For Cutting-off 合金裁板锯锯片	63
	603	TCT General Circular Saw Blade 合金通用型锯片	64
	604	TCT Circular Saw Blade For Scoring 合金划线专用锯片	64
	605	TCT Circular Saw Blade For Aluminum 铝合金专用合金锯片	65
	606	TCT Circular Saw Blade For Ripping 合金电子开料锯锯片	65
	607	TCT Circular Saw Blade For Edge-Banding 合金封边锯锯片	66
	608	TCT Circular Saw Blade For Cross-Cutting 合金实木横截锯锯片	66
	609	TCT Circular Saw Blade For Ripping 合金纵切用锯片	67
	610	TCT Circular Saw Blade For Flush Trimming 合金修边锯锯片	67
	611	TCT Circular Saw Blade For Plywoos 合金胶合板专用锯片	67

CONTENTS

HSS & Carbide Replacement Insert Knife

高速钢与
合金舍弃式木工刀片



1202	Inserted Surfacing Bit With Replacement Insert 舍弃式木工T型刀	68
2007	Inserted V-Groove Bit With Replacement Insert 舍弃式木工V型刀	68
3186	HSS Planer Blade 高速钢木工刨刀片	69
3187	TCT Planer Blade 合金木工刨刀片	70
5025 5026	Solid Carbide Replacement Insert Knife 合金木工舍弃式刀片	71
5027	Solid Carbide Radius Profile Replacement Insert Knife 合金木工封边机刀片	71

CNC Accessory

CNC机床配件



5011	ER Collet ER夹头	73
5021	ER Wrench ER扳手	75
5014	ER Nut ER螺母	75
5080	Dust Chip Extraction Nut 吸尘螺母	76
5009	High Performance Ball Bearing ER Nut 高性能ER滚珠螺母	76
5102	CNC Tool Fork 卡爪	76
5012	Collet Adapter 变径套	77
5007	Quick Change Adapter 排钻钻套	77
5089	HSK-63F CNC Holder HSK-63F 刀柄	77
5088	BT30 & BT40 CNC Holder BT30 & BT40 刀柄	78
5132	ISO30 CNC Holder ISO30刀柄	78

The specifications, current at time of publication, are intended for reference purposes and are subject to change without notice.

© 2023 All rights reserved. No part of this catalog may be reproduced without written consent of Amana Tool Corp.

▶ 刀具使用事项

一、刀具操作注意事项

1. 本品牌刀具为专业使用者依不同的使用材料设计不同的刀具，主要分为五大类: 刨花板、中纤板、实木、亚克力和人造石，专业使用者需依照不同的材料选择不同刀具，以达到切削的最佳效果及耐用程度，避免刀具因过大的压力而扭断，所有的刀具均以顺时针旋转而设计。
2. 所有刀具在制作完成之际，均通过平衡检测，保证没有径跳的疑虑，为再次保障刀具在使用中无摆动和跳动，请注意选择及其设备和优良的夹套。
3. 夹套一定要选用合适尺寸，若发现夹套已有不够圆或是磨损的情况，会导致夹套无法正常且正确的夹紧刀具，请立即更换具有标准规格的夹套，避免刀具在高速旋转之下产生柄部震动，飞脱或扭断的危险情况。
4. 刀具柄部的装设应按照欧盟规定，例如12.7mm柄径的夹持深度必须达到24mm,以保持刀柄应有的压力承受范围。
5. 转速的设定:
外径较大的刀具应按照一下转速表设置，并缓慢推进，保持均匀的推进速度，切勿在切削过程中停止推进的动作。

如图：





建议铣刀转速(suggested router speeds)	
直径(Bit Diameter)	最高转速(Maximum speed)
1" (25mm)	24,000 RPM
1-1/4" -2" (30-50mm)	18,000 RPM
2-1/4" -2-1/2" (55-65mm)	16,000 RPM
3" -3-1/2" (75-90mm)	12,000 RPM

6. 当刀具使用钝了，请更换新的刀具，切勿继续使用，以免发生刀具断裂和工伤意外。
7. 使用刀具时请选用刀刃长度大于工作物件，例如:欲铣12.7深度的沟槽，请选用25.4mm刀刃长度的刀具，避免选用12.7mm或低于12.7mm的刀具。
8. 操作加工时，请使用者配戴安全眼镜，安全推把，使用桌上型机器设备时也需使用防反弹装置，避免工作物件在高速切削时反弹产生意外。

Instruction for tool operation

1. The knives of this brand are designed for professional users according to different materials. They are mainly divided into five categories: particle board, MDF, solid wood, acrylic and artificial stone. Choose different knives for the material to achieve the best cutting effect and durability, and avoid the knives from being twisted due to excessive pressure. All knives are designed to rotate clockwise.
2. All the knives have passed the balance test when the production is completed to ensure that there is no doubt about radial jump. In order to ensure that the cutters do not swing and jump during use again, please pay attention to the selection and equipment and excellent jackets.
3. The jacket must be of a suitable size. If it is found that the jacket is not round enough or worn out, it will cause the jacket to be unable to clamp the tool normally and correctly. Please replace the jacket with a standard specification immediately to avoid Under the high-speed rotation of the tool, the shank vibrates, and there is a danger of flying off or twisting off.
4. The installation of the tool handle should be in accordance with EU regulations, for example, the clamping depth of a 12.7mm shank diameter must reach 24mm, so as to maintain the proper pressure bearing range of the tool handle.
5. Speed setting:
The tool with a larger outer diameter should be set according to the following speed table, and it should be advanced slowly to maintain a uniform advancing speed. Do not stop the advancing action during the cutting process.
6. When the knife is blunt, please replace it with a new one, and do not continue to use it to avoid knife breakage and work-related accidents.
7. When using a tool, please use a tool with a blade length longer than the work object. For example, if you want to mill a groove with a depth of 12.7, please use a tool with a blade length of 25.4mm, and avoid using a tool with a blade length of 12.7mm or less than 12.7mm.
8. When operating and processing, users are required to wear safety glasses and safety push handles. When using desktop machines and equipment, anti-rebound devices are also required to avoid accidents caused by the rebound of the work object during high-speed cutting.

涂层分类

Coating Name	Color	Hardness (Hv)	Max Service Temperature (°C)	Friction Coefficient	Sample Picture
涂层名称	颜色	硬度	最大温度	摩擦系数	样刀图
TiN	Gold	2500	600	0.500	
AlTiN	Black	3500	900	0.400	
TiSiN	Bronze	3800	1100	0.250	
Nano AlTiN+	Black	4000	1200	0.250	
Nano TiSiN	Bronze	4000	1200	0.250	
Nano Blue	Blue	4000	1200	0.450	
DLC	Black	2500	300	0.100	
DLC	Rainbow	5000	150	0.080	



亚克力用单刃螺旋铣刀 Solid Carbide One Flute End Mill

1006

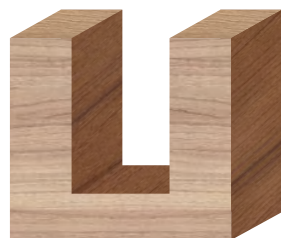

序号 NO	编号 Order No.	关键尺寸 Size	柄径 SHK	刃径 CED	刃长 CEL	总长 OVL
1	10060103	1*3	3.175	1	3	38
2	10060104	1*4	3.175	1	4	38
3	10061504	1.5*4	3.175	1.5	4	38
4	10061507	1.5*7	3.175	1.5	7	38
5	10061512	1.5*12	3.175	1.5	12	38
6	10060204	2*4	3.175	2	4	38
7	10060206	2*6	3.175	2	6	38
8	10060208	2*8	3.175	2	8	38
9	10060210	2*10	3.175	2	10	38
10	10060212	2*12	3.175	2	12	38
11	10060215	2*15	3.175	2	15	38
12	10060217	2*17	3.175	2	17	38
13	10060222	2*22	3.175	2	22	45
14	10062504	2.5*4	3.175	2.5	4	38
15	10062506	2.5*6	3.175	2.5	6	38
16	10062508	2.5*8	3.175	2.5	8	38
17	10062510	2.5*10	3.175	2.5	10	38
18	10062512	2.5*12	3.175	2.5	12	38
19	10062515	2.5*15	3.175	2.5	15	38
20	10062517	2.5*17	3.175	2.5	17	38
21	10062522	2.5*22	3.175	2.5	22	45
22	10063106	3.175*6	3.175	3.175	6	38
23	10063108	3.175*8	3.175	3.175	8	38
24	10063110	3.175*10	3.175	3.175	10	38
25	10063112	3.175*12	3.175	3.175	12	38
26	10063115	3.175*15	3.175	3.175	15	38
27	10063117	3.175*17	3.175	3.175	17	38
28	10063122	3.175*22	3.175	3.175	22	38
29	10063125	3.175*25	3.175	3.175	25	50
30	10063128	3.175*28	3.175	3.175	28	50
31	10063132	3.175*32	3.175	3.175	32	55
32	10063142	3.175*42	3.175	3.175	42	70
33	10063152	3.175*52	3.175	3.175	52	75
34	10060408	4*8	4	4	8	45
35	10060412	4*12	4	4	12	45
36	10060415	4*15	4	4	15	45

硬质合金CNC铣刀

PCB钻头与铣刀

合金木工钻头

合金花型刀

高速钢CNC铣刀
与钻头

金刚石&合金锯片

高速钢与合金套壳式
木工刀片

CNC机床配件

亚克力用单刃螺旋铣刀
Solid Carbide One Flute End Mill

1006

序号 NO	编号 Order No.	关键尺寸 Size	柄径 SHK	刃径 CED	刃长 CEL	总长 OVL
37	10060417	4*17	4	4	17	45
38	10060422	4*22	4	4	22	45
39	10060425	4*25	4	4	25	50
40	10060428	4*28	4	4	28	50
41	10060432	4*32	4	4	32	55
42	10060442	4*42	4	4	42	70
43	10060452	4*52	4	4	52	75
44	10060512	5*12	5	5	12	50
45	10060517	5*17	5	5	17	50
46	10060522	5*22	5	5	22	50
47	10060525	5*25	5	5	25	50
48	10060528	5*28	5	5	28	55
49	10060532	5*32	5	5	32	55
50	10060612	6*12	6	6	12	50
51	10060615	6*15	6	6	15	50
52	10060617	6*17	6	6	17	50
53	10060622	6*22	6	6	22	50
54	10060625	6*25	6	6	25	50
55	10060628	6*28	6	6	28	60
56	10060632	6*32	6	6	32	60
57	10060642	6*42	6	6	42	70
58	10060652	6*52	6	6	52	80
59	10060822	8*22	8	8	22	60
60	10060825	8*25	8	8	25	60
61	10060832	8*32	8	8	32	60
62	10060842	8*42	8	8	42	75
63	10060852	8*52	8	8	52	85
64	10060862	8*62	8	8	62	100
65	10061032	10*32	10	10	32	75
66	10061042	10*42	10	10	42	85
67	10061052	10*52	10	10	52	100
68	10061062	10*62	10	10	62	120
69	10061232	12*32	12	12	32	75
70	10061242	12*42	12	12	42	90
71	10061252	12*52	12	12	52	100
72	10061262	12*62	12	12	62	120
73	100612752	12.7*52	12.7	12.7	52	100

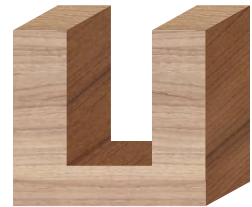

硬质合金CNC铣刀

PCB钻头与铣刀

合金木工钻头

合金花型刀

与钻头
高速钢CNC铣刀

金刚石&合金锯片

木工刀片
高速钢与合金合金式

CNC机床配件

单刃铝用刀

Solid Carbide One Flute End Mill For Aluminum

1015

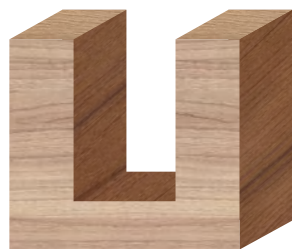
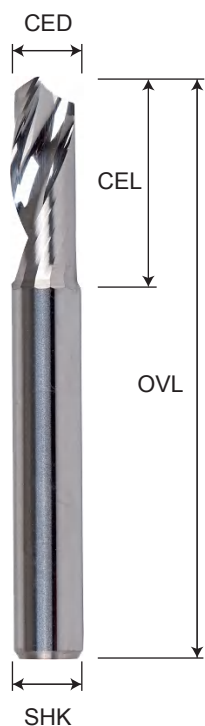

序号	编号	关键尺寸	柄径	刃径	刃长	总长
NO	Order No.	Size	SHK	CED	CEL	OVL
1	10153013	1*3	3.175	1	3	38
2	10153155	1.5*5	3.175	1.5	5	38
3	10153024	2*4	3.175	2	4	38
4	10153026	2*6	3.175	2	6	38
5	10083028	2*8	3.175	2	8	38
6	10153254	2.5*4	3.175	2.5	4	38
7	10153256	2.5*6	3.175	2.5	6	38
8	10153258	2.5*8	3.175	2.5	8	38
9	10153106	3.175*6	3.175	3.175	6	38
10	10153108	3.175*8	3.175	3.175	8	38
11	10153110	3.175*10	3.175	3.175	10	38
12	10153112	3.175*12	3.175	3.175	12	38
13	10153117	3.175*17	3.175	3.175	17	38
14	10150408	4*8	4	4	8	45
15	10150410	4*10	4	4	10	45
16	10150412	4*12	4	4	12	45
17	10150415	4*15	4	4	15	45
18	10150417	4*17	4	4	17	45
19	10150422	4*22	4	4	22	50
20	10150612	6*12	6	6	12	50
21	10150617	6*17	6	6	17	50
22	10150622	6*22	6	6	22	50
23	10150822	8*22	8	8	22	60
24	10150825	8*25	8	8	25	60
25	10151025	10*25	10	10	25	75
26	10151032	10*32	10	10	32	75
27	10151042	10*42	10	10	42	85
28	10151235	12*35	12	12	35	75
29	10151242	12*42	12	12	42	80

硬质合金CNC铣刀

PCB钻头与铣刀

合金车工钻头

合金花型刀

高速钢CNC铣刀
与钻头

金刚石&合金锯片

高速钢与合金舍壳式
木工刀片

CNC机床配件

亚克力单刃刀下切

Solid Carbide One Flute Dwoncut End Mill

1047

序号	编号	关键尺寸	柄径	刃径	刃长	总长
NO	Order No.	Size	SHK	CED	CEL	OVL
1	104730103	1*3	3.175	1	3	38
2	104731504	1.5*4	3.175	1.5	4	38
3	104731507	1.5*7	3.175	1.5	7	38
4	104731512	1.5*12	3.175	1.5	12	38
5	104730206	1.5*6	3.175	1.5	6	38
6	104730208	2*8	3.175	2	8	38
7	104730212	2*12	3.175	2	12	38
8	104730215	2*15	3.175	2	15	38
9	104730217	2*17	3.175	2	17	38
10	104732506	2.5*6	3.175	2.5	6	38
11	104732508	2.5*8	3.175	2.5	8	38
12	104732512	2.5*12	3.175	2.5	12	38
13	104732517	2.5*17	3.175	2.5	17	38
14	10473108	3.175*8	3.175	3.175	8	38
15	10473112	3.175*12	3.175	3.175	12	38
16	10473115	3.175*15	3.175	3.175	15	38
17	10473117	3.175*17	3.175	3.175	17	38
18	10473122	3.175*22	3.175	3.175	22	45
19	10473125	3.175*25	3.175	3.175	25	50
20	10473128	3.175*28	3.175	3.175	28	50
21	10473132	3.175*32	3.175	3.175	32	55
22	10470412	4*12	4	4	12	45
23	10470417	4*17	4	4	17	45
24	10470422	4*22	4	4	22	45
25	10470425	4*25	4	4	25	50
26	10470428	4*28	4	4	28	55
27	10470432	4*32	4	4	32	60
28	10470517	5*17	5	5	17	50
29	10470522	5*22	5	5	22	50
30	10470525	5*25	5	5	25	50
31	10470528	5*28	5	5	28	55
32	10470532	5*32	5	5	32	60
33	10470617	6*17	6	6	17	50
34	10470622	6*22	6	6	22	50
35	10470625	6*25	6	6	25	50
36	10470632	6*32	6	6	32	70
37	1470642	6*42	6	6	42	80
38	10470825	8*25	8	8	25	60
39	10470832	8*32	8	8	32	70
40	10470842	8*42	8	8	42	80

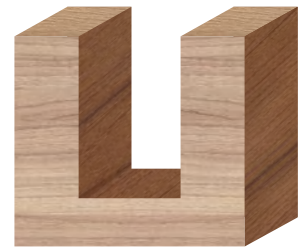
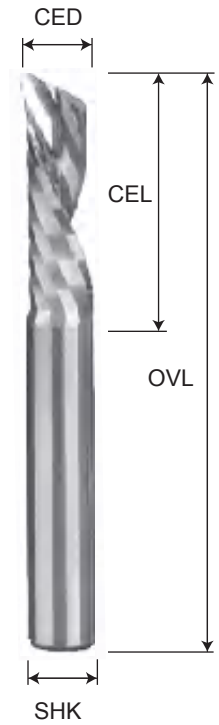

硬质合金CNC铣刀

PCB钻头与铣刀

合金木工钻头

合金花型刀

与钻头
高速钢CNC铣刀

金刚石及合金锯片

木工刀片
高速钢与合金合金式

CNC机床配件

二刃木工螺旋铣刀

Solid Carbide Two Flutes Spiral End Mill

1011

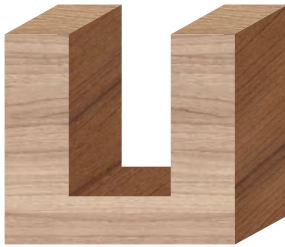
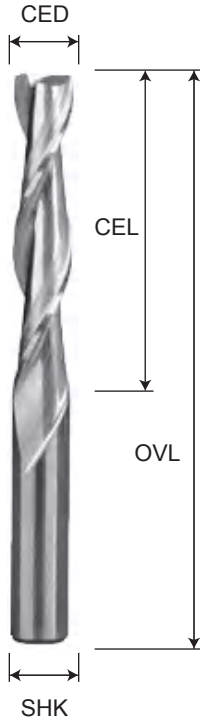

序号	编号	关键尺寸	柄径	刃径	刃长	总长
NO	Order No.	Size	SHK	CED	CEL	OVL
1	10110104	1*4	3.175	1	4	38
2	10111506	1.5*6	3.175	1.5	6	38
3	10111508	1.5*8	3.175	1.5	8	38
4	10111512	1.5*12	3.175	1.5	12	38
5	10110208	2*8	3.175	2	8	38
6	10110212	2*12	3.175	2	12	38
7	10110217	2*17	3.175	2	17	38
8	10110222	2*22	3.175	2	22	45
9	10112512	2.5*12	3.175	2.5	12	38
10	10112517	2.5*17	3.175	2.5	17	38
11	10112522	2.5*22	3.175	2.5	22	45
12	10113112	3.175*12	3.175	3.175	12	38
13	10113115	3.175*15	3.175	3.175	15	38
14	10113117	3.175*17	3.175	3.175	17	38
15	10113122	3.175*22	3.175	3.175	22	45
16	10113125	3.175*25	3.175	3.175	25	50
17	10113128	3.175*28	3.175	3.175	28	50
18	10113132	3.175*32	3.175	3.175	32	55
19	10113142	3.175*42	3.175	3.175	42	65
20	10113152	3.175*52	3.175	3.175	52	75
21	10110412	4*12	4	4	12	40
22	10110415	4*15	4	4	15	40
23	10110417	4*17	4	4	17	45
24	10110422	4*22	4	4	22	45
25	10110425	4*25	4	4	25	50
26	10110428	4*28	4	4	28	55
27	10110432	4*32	4	4	32	60
28	10110442	4*42	4	4	42	70
29	10110452	4*52	4	4	52	80
30	10110517	5*17	5	5	17	45
31	10110522	5*22	5	5	22	50
32	10110525	5*25	5	5	25	50
33	10110528	5*28	5	5	28	55
34	10110532	5*32	5	5	32	60
35	10110617	6*17	6	6	17	45
36	10110622	6*22	6	6	22	50
37	10110625	6*25	6	6	25	50
38	10110628	6*28	6	6	28	60
39	10110632	6*32	6	6	32	60
40	10110642	6*42	6	6	42	70

硬质合金CNC铣刀

PCB钻头与铣刀

合金木工钻头

合金花型刀

高速钢CNC铣刀与钻头

金刚石&合金锯片

高速钢与合金套壳式木工刀片

CNC机床配件

二刃木工螺旋铣刀

Solid Carbide Two Flutes Spiral End Mill

1011

序号	编号	关键尺寸	柄径	刃径	刃长	总长
NO	Order No.	Size	SHK	CED	CEL	OVL
41	10110652	6*52	6	6	52	80
42	10110662	6*62	6	6	62	100
43	10110825	8*25	8	8	25	60
44	10110832	8*32	8	8	32	60
45	10110842	8*42	8	8	42	80
46	10110852	8*52	8	8	52	90
47	10111032	10*32	10	10	32	70
48	10111042	10*42	10	10	42	80
49	10111052	10*52	10	10	52	100
50	10111062	10*62	10	10	62	110
51	10111232	12*32	12	12	32	70
52	10111242	12*42	12	12	42	80
53	10111252	12*52	12	12	52	100
54	10111262	12*62	12	12	62	110
55	10111280	12*80	12	12	80	120
56	101112742	12.7*42	12.7	12.7	42	90
57	101112752	12.7*52	12.7	12.7	52	100
58	101112762	12.7*62	12.7	12.7	62	110
59	101112780	12.7*80	12.7	12.7	80	120
60	10111442	14*42	14	14	42	90
61	10111452	14*52	14	14	52	100
62	10111642	16*42	16	16	42	90
63	10111652	16*52	16	16	52	100
64	10111662	16*62	16	16	62	110
65	10111672	16*72	16	16	72	120
66	10111852	18*52	18	18	52	100
67	10111872	18*72	18	18	72	120
68	10112052	20*52	20	20	52	100
69	10112062	20*62	20	20	62	110
70	10112072	20*72	20	20	72	120

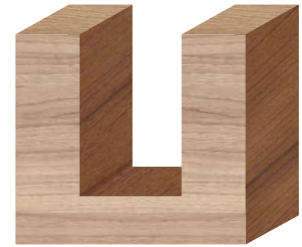
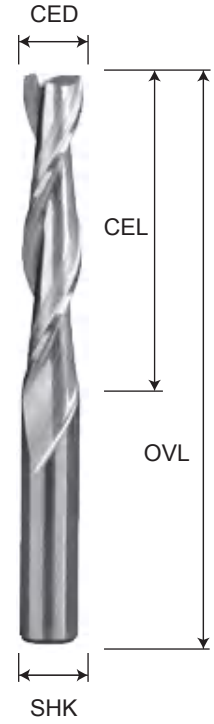

硬质合金CNC铣刀

PCB钻头与铣刀

合金木工钻头

合金花型刀

与钻头
高速钢CNC铣刀

金刚石&合金锯片

木工刀片
高速钢与合金合金式

CNC机床配件

硬质合金CNC铣刀

PCB钻头与铣刀

合金木铣头

合金花型刀

高速钢CNC铣刀
与钻头

金刚石&合金锯片

高速钢与合金套式
木工刀片

CNC机床配件

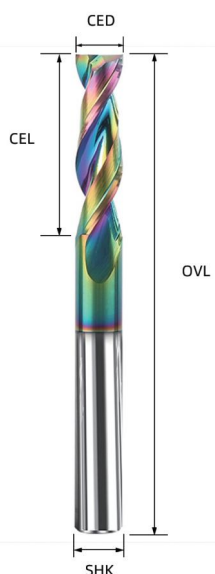
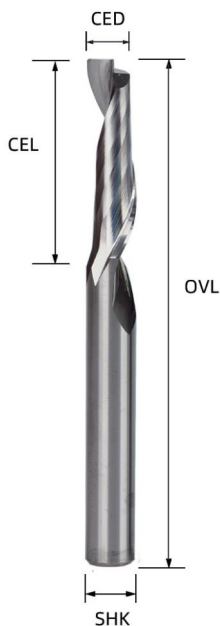

钨钢单刃铝型材仿型铣刀

Solid Carbide One Flute End Mill For Aluminum Profile

3098

序号 NO	编号 Order No.	关键尺寸 Size	柄径 SHK	刃径 CED	刃长 CEL	总长 OVL
1	30983146	d3*12*D8*60L	8	3	14	60
2	30984146	d4*14*D8*60L	8	4	14	60
3	30985146	d5*14*D8*60L	8	5	14	60
4	30985168	d5*14(35)*D8*80L	8	5	14(35)	80
5	30985169	d5*16(45)*D8*90L	8	5	16(45)	90
6	309851610	d5*16(45)*D8*100L	8	5	16(45)	100
7	30986146	d6*14*D8*60L	8	6	14	60
8	30986208	d6*14(35)*D8*80L	8	6	14(35)	80
9	30986209	d6*16(45)*D8*90L	8	6	16(45)	90
10	309862010	d6*16(45)*D8*100L	8	6	16(45)	100
11	309873010	d7*30(70)*D8*100L	8	7	30(70)	100
12	30988208	d8*20*D8*80L	8	8	20	80
13	309883710	d8*30(70)*D8*100L	8	8	30(70)	100
14	309883010	d8*30*D8*100L	8	8	30	100
15	309883012	d8*30(70)*D8*120L	8	8	30(70)	120
16	309810208	d10*14*D10*80L	10	10	14	80
17	3098103010	d10*30(70)*D10*100L	10	10	30(70)	100
18	3098103012	d10*30(70)*D10*120L	10	10	30(70)	120
19	309812208	d12*16*D12*80L	12	12	16	80
20	3098123010	d12*30(70)*D12*100L	12	12	30(70)	100
21	3098123012	d12*30(70)*D12*120L	12	12	30(70)	120

二刃铝型材仿型铣刀

Solid Carbide Two Flutes Square End Mill For Aluminum Profile

1119

序号 NO	编号 Order No.	关键尺寸 Size	刃径 CED	刃长 CEL	柄径 CEL	总长 OVL
1	11190650	6*18*6*50	6	18	6	50
2	11190675	6*25*6*75	6	25	6	75
3	11190880	8*30*8*80	8	30	8	80
4	111908100	8*30*8*100	8	30	8	100
5	11190580	5*25*8*80	5	25	8	80
6	111906100	6*25*8*100	6	25	8	100

铝型材台阶钻

Solid Carbide Step Drill Bit For Aluminum Profile

1192

序号 NO	编号 Order No.	产品规格 Size	刃径 CED	刃长 CEL	柄径 SHK	全长 OVL	倒角位置 A
1	11920250	2*5*4*50	2	5	4	50	90°
2	11922250	2.2*5*4*50	2.2	5	4	50	90°
3	119225450	2.5*5*4*50	2.5	5	4	50	90°
4	119225650	2.5*6*6*50	2.5	6	6	50	90°
5	11920350	3*6*6*50	3	6	6	50	90°
6	11923450	3.4*6*6*50	3.4	6	6	50	90°
7	11923550	3.5*6*6*50	3.5	6	6	50	90°
8	11923275	3.2*6*8*75	3.2	6	8	75	90°
9	11923575	3.5*6*8*75	3.5	6	8	75	90°
10	11924275	4.2*6*8*75	4.2	6	8	75	90°
11	11924575	4.5*6*8*75	4.5	6	8	75	90°
12	11920575	5*6*8*75	5	6	8	75	90°
13	11925275	5.2*8*8*75	5.2	8	8	75	90°
14	119205175	5*10*10*75	5	10	10	75	90°
15	11920675	6*10*10*75	6	10	10	75	90°
16	119208075	8*10*10*75	8	10	10	75	90°
17	119208475	8*14*10*75	8	14	10	75	90°
18	1192081875	8*18*10*75	8	18	10	75	90°
19	1192081275	8*18*12*75	8	18	12	75	90°



硬质合金CNC铣刀

PCB钻头与铣刀

合金木工钻头

合金花型刀

与钻头
高速钢CNC铣刀

金刚石&合金锯片

木工刀片
高速钢与合金合金式

CNC机床配件



三刃木工螺旋铣刀

Solid Carbide Three Flutes Spiral End Mill

1013

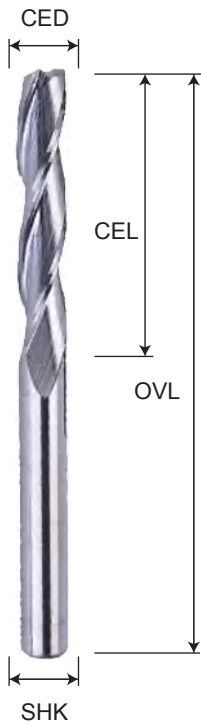

序号	编号	关键尺寸	柄径	刃径	刃长	总长
NO	Order No.	Size	SHK	CED	CEL	OVL
1	10130625	6*25	6	6	25	50
2	10130630	6*30	6	6	30	60
3	10130640	6*40	6	6	40	80
4	10130650	6*50	6	6	50	100
5	10130830	8*30	8	8	30	60
6	10130835	8*35	8	8	35	75
7	10130842	8*42	8	8	42	80
8	10130850	8*50	8	8	50	100
9	10131032	10*32	10	10	32	70
10	10131035	10*35	10	10	35	75
11	10131042	10*42	10	10	42	90
12	10131052	10*52	10	10	52	100
13	10131062	10*62	10	10	62	110
14	10131235	12*35	12	12	35	75
15	10131250	12*50	12	12	50	100
16	10131260	12*60	12	12	60	110
17	10131270	12*70	12	12	70	120
18	101312742	12.7*42	12.7	12.7	42	90
19	101312750	12.7*50	12.7	12.7	50	100
20	101312760	12.7*60	12.7	12.7	60	110
21	101312770	12.7*70	12.7	12.7	70	120
22	101312780	12.7*80	12.7	12.7	80	130
23	10131442	14*42	14	14	42	90
24	10131452	14*52	14	14	52	100
25	10131462	14*62	14	14	62	110
26	10131472	14*72	14	14	72	120
27	10131642	16*42	16	16	42	90
28	10131652	16*52	16	16	52	100
29	10131662	16*62	16	16	62	110
30	10131672	16*72	16	16	72	120
31	10131690	16*90	16	16	90	150
32	10131852	18*52	18	18	52	100
33	10131862	18*62	18	18	62	110
34	10131872	18*72	18	18	72	120
35	101318102	18*102	18	18	102	150
36	10132052	20*52	20	20	52	100
37	10132062	20*62	20	20	62	110
38	10132072	20*72	20	20	72	120
39	10132085	20*85	20	20	85	140
40	101320102	20*102	20	20	102	150

硬质合金CNC铣刀

PCB钻头与铣刀

合金平头钻头

合金花型刀

高速钢CNC铣刀与钻头

金刚石&合金锯片

高速钢与合金舍斧式木工刀片

CNC机床配件

二刃木工球头铣刀

Solid Carbide Two Flutes Ball Nose End Mill

1017

序号	编号	关键尺寸	柄径	刃径	半径	刃长	总长
NO	Order No.	Size	SHK	CED	R	CEL	OVL
1	10170104	R0.5*4	3.175	1	0.5	4	38
2	10171506	R0.75*6	3.175	1.5	0.75	6	38
3	10170208	R1*8	3.175	2	1	8	38
4	10170212	R1*12	3.175	2	1	12	38
5	10170217	R1*17	3.175	2	1	17	38
6	10170222	R1*22	3.175	2	1	22	45
7	10172512	R1.25*12	3.175	2.5	1.25	12	38
8	10172517	R1.25*17	3.175	2.5	1.25	17	38
9	10172522	R1.25*22	3.175	2.5	1.25	22	45
10	10173112	R1.59*12	3.175	3.175	1.59	12	38
11	10173115	R1.59*15	3.175	3.175	1.59	15	38
12	10173117	R1.59*17	3.175	3.175	1.59	17	38
13	10173122	R1.59*22	3.175	3.175	1.59	22	45
14	10173125	R1.59*25	3.175	3.175	1.59	25	50
15	10173128	R1.59*28	3.175	3.175	1.59	28	55
16	10173132	R1.59*32	3.175	3.175	1.59	32	55
17	10170412	R2*12	4	4	2	12	40
18	10170415	R2*15	4	4	2	15	40
19	10170417	R2*17	4	4	2	17	45
20	10170422	R2*22	4	4	2	22	45
21	10170425	R2*25	4	4	2	25	50
22	10170428	R2*28	4	4	2	28	55
23	10170432	R2*32	4	4	2	32	60
24	10170442	R2*42	4	4	2	42	70
25	10170452	R2*52	4	4	2	52	80
26	10170617	R3*17	6	6	3	17	45
27	10170622	R3*22	6	6	3	22	50
28	10170625	R3*25	6	6	3	25	50
29	10170628	R3*28	6	6	3	28	60
30	10170632	R3*32	6	6	3	32	60
31	10170642	R3*42	6	6	3	42	70
32	10170652	R3*52	6	6	3	52	80
33	10170825	R4*25	8	8	4	25	60
34	10170832	R4*32	8	8	4	32	60
35	10170842	R4*42	8	8	4	42	80
36	10170852	R4*52	8	8	4	52	90

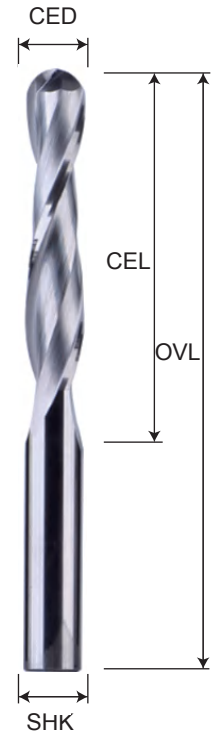

硬质合金CNC铣刀

PCB钻头与铣刀

合金木工钻头

合金花型刀

与钻头
高速钢CNC铣刀

金刚石&合金锯片

木工刀片
高速钢与合金套式

CNC机床配件

二刃木工球头铣刀

Solid Carbide Two Flutes Ball Nose End Mill

1017

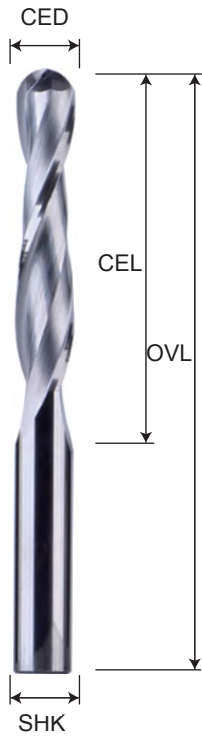

序号	编号	关键尺寸	柄径	刃径	半径	刃长	总长
NO	Order No.	Size	SHK	CED	R	CEL	OVL
37	10171032	R5*32	10	10	5	32	70
38	10171042	R5*42	10	10	5	42	80
39	10171052	R5*52	10	10	5	52	100
40	10171062	R5*62	10	10	5	62	110
41	10171232	R6*32	12	12	6	32	70
42	10171242	R6*42	12	12	6	42	80
43	10171252	R6*52	12	12	6	52	100
44	10171262	R6*62	12	12	6	62	110
45	10171280	R6*80	12	12	6	80	120
46	101712742	R6.35*42	12.7	12.7	6.35	42	90
47	101712752	R6.35*52	12.7	12.7	6.35	52	100
48	101712762	R6.35*62	12.7	12.7	6.35	62	110
49	101712780	R6.35*80	12.7	12.7	6.35	80	120
50	10171442	R7*42	14	14	7	42	90
51	10171452	R7*52	14	14	7	52	100
52	10171642	R8*42	16	16	8	42	90
53	10171652	R8*52	16	16	8	52	100
54	10171662	R8*62	16	16	8	62	110
55	10171672	R8*72	16	16	8	72	120
56	10171852	R9*52	18	18	9	52	100
57	10171872	R9*72	18	18	9	72	120
58	10172052	R10*52	20	20	10	52	100
59	10172062	R10*62	20	20	10	62	110
60	10172072	R10*72	20	20	10	72	120

硬质合金CNC铣刀

PCB钻头与铣刀

合金车工钻头

合金花型刀

高速钢CNC铣刀
与钻头

金刚石&合金锯片

高速钢与合金卷式
木工刀片

CNC机床配件

二刃木工锥度球头铣刀

Solid Carbide Two Flutes Tapered Ball Nose End Mill

1028

序号	编号	关键尺寸	柄径	半径	直径	刃长	总长
NO	Order No.	Size	SHK	R	CED	CEL	OVL
1	102832538	R0.25*15	3.175	0.25	0.5	15	38
2	102830538	R0.5*15	3.175	0.5	1	15	38
3	102842550	R0.25*15	4	0.25	0.5	15	50
4	102840550	R0.5*15	4	0.5	1	15	50
5	102847550	R0.75*15	4	0.75	1.5	15	50
6	102841050	R1*15	4	1	2	15	50
7	102842520	R0.25*20.5	4	0.25	0.5	20.5	50
8	102840520	R0.5*20.5	4	0.5	1	20.5	50
9	102847520	R0.75*20.5	4	0.75	1.5	20.5	50
10	102841020	R1*20.5	4	1	2	20.5	50
11	102842575	R0.25*20.5	4	0.25	0.5	20.5	75
12	102840575	R0.5*20.5	4	0.5	1	20.5	75
13	102862550	R0.25*20.5	6	0.25	0.5	20.5	50
14	102860550	R0.5*20.5	6	0.5	1	20.5	50
15	102867550	R0.75*20.5	6	0.75	1.5	20.5	50
16	102862575	R0.25*30.5	6	0.25	0.5	30.5	75
17	102860575	R0.5*30.5	6	0.5	1	30.5	75
18	102867575	R0.75*30.5	6	0.75	1.5	30.5	75
19	102861075	R1*30.5	6	1	2	30.5	75
20	102861575	R1.5*30.5	6	1.5	3	30.5	75
21	102862075	R2*30.5	6	2	4	30.5	75
22	102862010	R2*60	6	2	4	60	100
23	102880585	R0.5*47	8	0.5	1	47	85
24	102881085	R1*47	8	1	2	47	85
25	102881585	R1.5*47	8	1.5	3	47	85
26	102882085	R2*47	8	2	4	47	85
27	102880510	R0.5*60	8	0.5	1	60	100
28	102881010	R1*60	8	1	2	60	100
29	102881510	R1.5*60	8	1.5	3	60	100
30	102882010	R2*60	8	2	4	60	100
31	102812011	R2*70	10	2	4	70	110
32	102812212	R2*70	12	2	4	70	120
33	102812215	R2*100	12	2	4	100	150

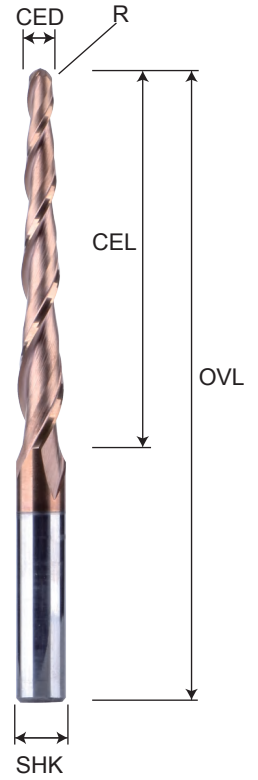

硬质合金CNC铣刀

PCB钻头与铣刀

合金木工钻头

合金花型刀

与钻头
高速钢CNC铣刀

金刚石及合金锯片

木工刀片
高速钢与合金套式

CNC机床配件

二刃木工复合铣刀

Solid Carbide Two Flutes Compression Up&Downcut End Mill

1036

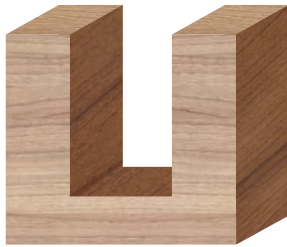
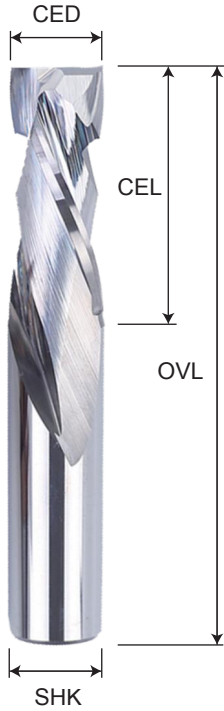

序号	编号	关键尺寸	柄径	刃径	刃长	总长
NO	Order No.	Size	SHK	CED	CEL	OVL
1	10363112	3.175*12	3.175	3.175	12	50
2	10363115	3.175*15	3.175	3.175	15	50
3	10363117	3.175*17	3.175	3.175	17	50
4	10363122	3.175*22	3.175	3.175	22	50
5	10360417	4*17	4	4	17	45
6	10360422	4*22	4	4	22	50
7	10360425	4*25	4	4	25	55
8	10360432	4*32	4	4	32	70
9	10360517	5*17	5	5	17	50
10	10360522	5*22	5	5	22	50
11	10360617	6*17	6	6	17	50
12	10360622	6*22	6	6	22	50
13	10360625	6*25	6	6	25	60
14	10360632	6*32	6	6	32	70
15	10360822	8*22	8	8	22	60
16	10360825	8*25	8	8	25	60
17	10360832	8*32	8	8	32	70
18	10360845	8*45	8	8	45	80
19	10361035	10*35	10	10	35	75
20	10361045	10*45	10	10	45	90
21	10361052	10*52	10	10	52	100
22	10361235	12*35	12	12	35	80
23	10361252	12*52	12	12	52	100
24	103612735	12.7*35	12.7	12.7	35	80
25	103612752	12.7*52	12.7	12.7	52	100
26	10361452	14*52	14	14	52	100
27	10361652	16*52	16	16	52	110
28	10361662	16*62	16	16	62	120
29	10361672	16*72	16	16	72	130
30	10361852	18*52	18	18	52	110
31	10361872	18*72	18	18	72	130
32	10362052	20*52	20	20	52	120
33	10362072	20*72	20	20	72	130

硬质合金CNC铣刀

PCB钻头与铣刀

合金木工钻头

合金花型刀

高速钢CNC铣刀
与钻头

金刚石&合金锯片

高速钢与合金套式
木工刀片

CNC机床配件

三刃木工复合铣刀

Solid Carbide Three Flutes Compression Up&Downcut End Mill

1038

序号	编号	关键尺寸	柄径	刃径	刃长	总长
NO	Order No.	Size	SHK	CED	CEL	OVL
1	10380617	6*17	6	6	17	50
2	10380622	6*22	6	6	22	50
3	10380625	6*25	6	6	25	60
4	10380632	6*32	6	6	32	70
5	10380822	8*22	8	8	22	60
6	10380825	8*25	8	8	25	60
7	10380832	8*32	8	8	32	70
8	10380845	8*45	8	8	45	80
9	10381035	10*35	10	10	35	75
10	10381045	10*45	10	10	45	90
11	10381052	10*52	10	10	52	100
12	10381235	12*35	12	12	35	80
13	10381252	12*52	12	12	52	100
14	103812735	12.7*35	12.7	12.7	35	80
15	103812752	12.7*52	12.7	12.7	52	100
16	10381452	14*52	14	14	52	100
17	10381652	16*52	16	16	52	110
18	10381662	16*62	16	16	62	120
19	10381672	16*72	16	16	72	130
20	10381852	18*52	18	18	52	110
21	10381872	18*72	18	18	72	130
22	10382052	20*52	20	20	52	120
23	10382072	20*72	20	20	72	130

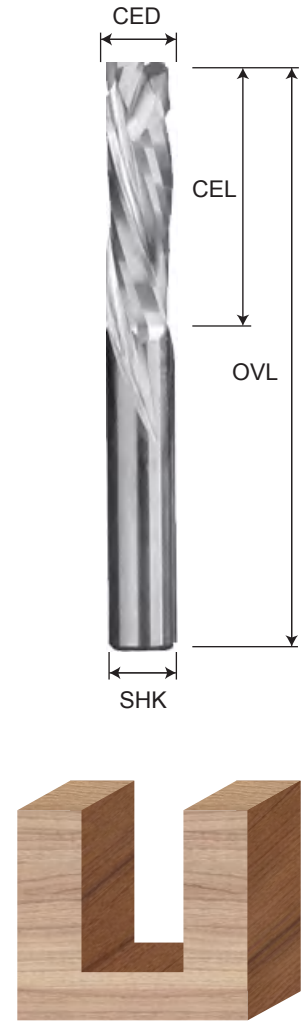

硬质合金CNC铣刀

PCB钻头与铣刀

合金木工钻头

合金花型刀

与钻头
高速钢CNC铣刀

金刚石&合金锯片

木工刀片
高速钢与合金合金式

CNC机床配件

玉米铣刀

Solid Carbide Corn End Mill

1008

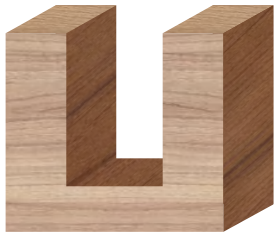
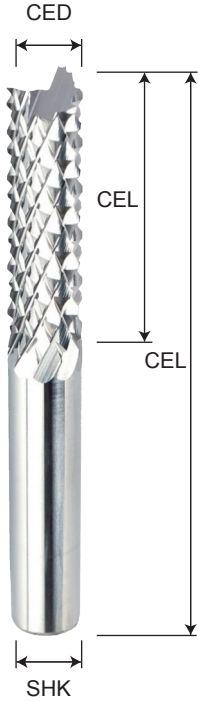

序号	编号	关键尺寸	柄径	刃径	刃长	总长
NO	Order No.	Size	SHK	CED	CEL	OVL
1	10080403	0.4*3	3.175	0.4	3	38
2	10080503	0.5*3	3.175	0.5	3	38
3	10080604	0.6*4	3.175	0.6	4	38
4	10080704	0.7*4	3.175	0.7	4	38
5	10080805	0.8*5	3.175	0.8	5	38
6	10080906	0.9*6	3.175	0.9	6	38
7	10081007	1*7	3.175	1	7	38
8	10081207	1.2*7	3.175	1.2	7	38
9	10081408	1.4*8	3.175	1.4	8	38
10	10081508	1.5*8	3.175	1.5	8	38
11	10081809	1.8*9	3.175	1.8	9	38
12	10082010	2*10	3.175	2	10	38
13	10082512	2.5*12	3.175	2.5	12	38
14	10083012	3*12	3.175	3	12	38
15	10083112	3.175*12	3.175	3.175	12	38
16	10083115	3.175*15	3.175	3.175	15	38
17	10083117	3.175*17	3.175	3.175	17	38
18	10083122	3.175*22	3.175	3.175	22	45
19	10083125	3.175*25	3.175	3.175	25	45
20	10084012	4*12	4	4	12	45
21	10084015	4*15	4	4	15	45
22	10084017	4*17	4	4	17	45
23	10084022	4*22	4	4	22	45
24	10084025	4*25	4	4	25	50
25	10084028	4*28	4	4	28	50
26	10084032	4*32	4	4	32	55
27	10086017	6*17	6	6	17	50
28	10086022	6*22	6	6	22	50
29	10086025	6*25	6	6	25	50
30	10086028	6*28	6	6	28	60
31	10086032	6*32	6	6	32	60
32	10086042	6*42	6	6	42	75
33	10086052	6*52	6	6	52	85
34	10086062	6*62	6	6	62	100
35	10088025	8*25	8	8	25	60
36	10088032	8*32	8	8	32	60
37	10088035	8*35	8	8	35	75
38	10088042	8*42	8	8	42	75
39	10088052	8*52	8	8	52	90
40	10081042	10*42	10	10	42	75

硬质合金CNC铣刀

PCB钻头与铣刀

合金木工钻头

合金花型刀

高速钢CNC铣刀
与钻头

金刚石及合金锯片

高速钢与合金舍弃式
木工刀片

CNC机床配件

玉米铣刀

Solid Carbide Corn End Mill

1008

序号	编号	关键尺寸	柄径	刃径	刃长	总长
NO	Order No.	Size	SHK	CED	CEL	OVL
41	10081052	10*52	10	10	52	100
42	10081242	12*42	12	12	42	75
43	10081255	12*55	12	12	55	100

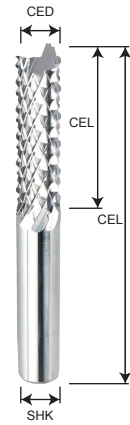

三刃半波刃粗皮铣刀

Solid Carbide Three Flutes Roughing and Finishing End Mill

1075

序号	编号	关键尺寸	刃径	刃长	波刃长	柄径	总长
NO	Order No.	Size	CED	CEL	I	SHK	OVL
1	10751655	16*105 (55)	16	105	55	16	165
2	10751855	18*105 (55)	18	105	55	16	165
3	10752055	20*105 (55)	20	105	55	16	165
4	10752255	22*105 (55)	22	105	55	16	165

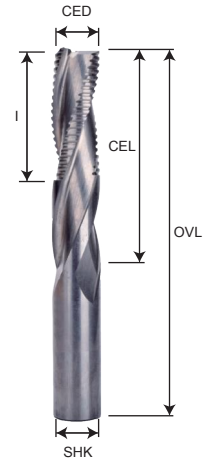

三刃木工粗皮铣刀

Solid Carbide Three Flutes Roughing End Mill

1030

序号	编号	关键尺寸	柄径	刃径	刃长	总长
NO	Order No.	Size	SHK	CED	CEL	OVL
1	10300625	6*25	6	6	25	60
2	10300632	6*32	6	6	32	70
3	10300635	6*35	6	6	35	75
4	10300642	6*42	6	6	42	80

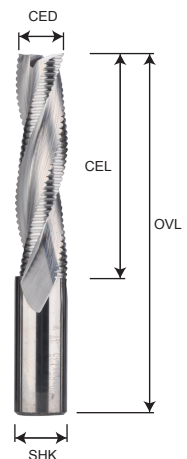

硬质合金CNC铣刀

PCB钻头与铣刀

合金木工钻头

合金花型刀

与钻头
高速钢CNC铣刀

金刚石&合金锯片

木工刀片
高速钢与合金套壳式

CNC机床配件



三刃木工粗皮铣刀

Solid Carbide Three Flutes Roughing End Mill

1030

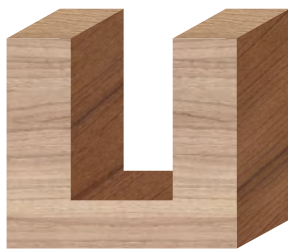
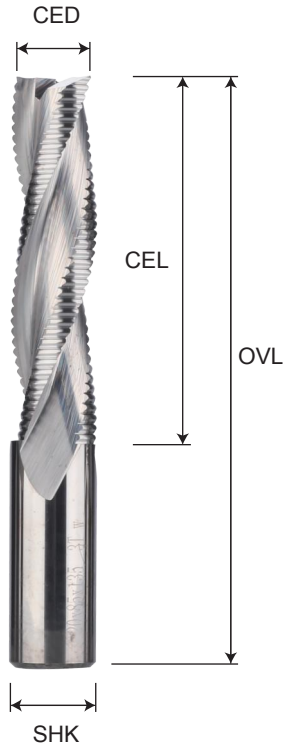

序号	编号	关键尺寸	柄径	刃径	刃长	总长
NO	Order No.	Size	SHK	CED	CEL	OVL
5	10300650	6*50	6	6	50	100
6	10300825	8*25	8	8	25	60
7	10300832	8*32	8	8	32	70
8	10300835	8*35	8	8	35	75
9	10300842	8*42	8	8	42	80
10	10300855	8*55	8	8	55	100
11	10301035	10*35	10	10	35	75
12	10301045	10*45	10	10	45	90
13	10301055	10*55	10	10	55	100
14	10301235	12*35	12	12	35	75
15	10301250	12*50	12	12	50	100
16	10301260	12*60	12	12	60	110
17	10301270	12*70	12	12	70	120
18	10301280	12*80	12	12	80	130
19	103012100	12*100	12	12	100	150
20	10301273	12.7*35	12.7	12.7	35	75
21	10301275	12.7*50	12.7	12.7	50	100
22	10301276	12.7*60	12.7	12.7	60	110
23	10301277	12.7*70	12.7	12.7	70	120
24	10301278	12.7*80	12.7	12.7	80	130
25	10301271	12.7*100	12.7	12.7	100	150
26	10301452	14*52	14	14	52	100
27	10301460	14*60	14	14	60	110
28	10301470	14*70	14	14	70	120
29	10301652	16*52	16	16	52	100
30	10301662	16*62	16	16	62	110
31	10301672	16*72	16	16	72	120
32	10301682	16*82	16	16	82	130
33	103016100	16*100	16	16	100	150
34	10301852	18*52	18	18	52	100
35	10301862	18*62	18	18	62	110
36	10301872	18*72	18	18	72	120
37	103018100	18*100	18	18	100	150
38	10302052	20*52	20	20	52	100
39	10302062	20*62	20	20	62	110
40	10302072	20*72	20	20	72	120
41	10302085	20*85	20	20	85	140
42	103020100	20*100	20	20	100	150

硬质合金CNC铣刀

PCB钻头与铣刀

合金木工钻头

合金花型刀

与钻头
高速钢CNC铣刀

金刚石&合金锯片

木工刀片
高速钢与合金舍弃式

CNC机床配件

二刃直槽铣刀

Solid Carbide Two Flutes Straight Slot End Mill

1020

序号	编号	关键尺寸	柄径	刃径	刃长	总长
NO	Order No.	Size	SHK	CED	CEL	OVL
1	10200103	1*3	3.175	1	3	38
2	10201504	1.5*4	3.175	1.5	4	38
3	10201507	1.5*7	3.175	1.5	7	38
4	10201512	1.5*12	3.175	1.5	12	38
5	10200208	2*8	3.175	2	8	38
6	10200212	2*12	3.175	2	12	38
7	10200217	2*17	3.175	2	17	38
8	10202512	2.5*12	3.175	2.5	12	38
9	10202515	2.5*15	3.175	2.5	15	38
10	10202517	2.5*17	3.175	2.5	17	38
11	10202522	2.5*22	3.175	2.5	22	45
12	10203112	3.175*12	3.175	3.175	12	38
13	10203115	3.175*15	3.175	3.175	15	38
14	10203117	3.175*17	3.175	3.175	17	38
15	10203122	3.175*22	3.175	3.175	22	45
16	10203125	3.175*25	3.175	3.175	25	50
17	10203128	3.175*28	3.175	3.175	28	50
18	10203132	3.175*32	3.175	3.175	32	55
19	10200412	4*12	4	4	12	45
20	10200417	4*17	4	4	17	45
21	10200422	4*22	4	4	22	45
22	10200425	4*25	4	4	25	50
23	10200428	4*28	4	4	28	55
24	10200432	4*32	4	4	32	55
25	10200442	4*42	4	4	42	65
26	10200617	6*17	6	6	17	45
27	10200622	6*22	6	6	22	50
28	10200625	6*25	6	6	25	50
29	10200628	6*28	6	6	28	60
30	10200632	6*32	6	6	32	60
31	10200642	6*42	6	6	42	70
32	10200652	6*52	6	6	52	80
33	10200662	6*62	6	6	62	100
34	10200825	8*25	8	8	25	60
35	10200832	8*32	8	8	32	60
36	10200842	8*42	8	8	42	80
37	10200852	8*52	8	8	52	90
38	10201032	10*32	10	10	32	70
39	10201042	10*42	10	10	42	80
40	10201052	10*52	10	10	52	100

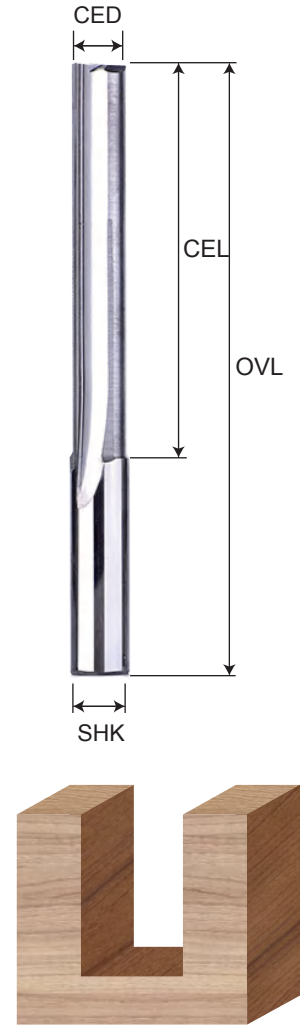

硬质合金CNC铣刀

PCB钻头与铣刀

合金木工钻头

合金花型刀

与钻头
高速钢CNC铣刀

金刚石及合金锯片

木工刀片
高速钢与合金套式

CNC机床配件



二刃直槽铣刀

Solid Carbide Two Flutes Straight Slot End Mill

1020

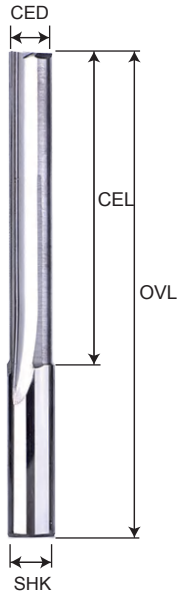

序号	编号	关键尺寸	柄径	刃径	刃长	总长
NO	Order No.	Size	SHK	CED	CEL	OVL
41	10201062	10*62	10	10	62	110
42	10201232	12*32	12	12	32	70
43	10201242	12*42	12	12	42	80
44	10201252	12*52	12	12	52	100
45	10201262	12*62	12	12	62	110
46	10201280	12*80	12	12	80	120
47	102012742	12.7*42	12.7	12.7	42	90
48	102012752	12.7*52	12.7	12.7	52	100
49	102012762	12.7*62	12.7	12.7	62	110
50	102012780	12.7*80	12.7	12.7	80	120
51	10201442	14*42	14	14	42	90
52	10201452	14*52	14	14	52	100
53	10201642	16*42	16	16	42	90
54	10201652	16*52	16	16	52	100
55	10201662	16*62	16	16	62	110
56	10201672	16*72	16	16	72	120
57	10201852	18*52	18	18	52	100
58	10201872	18*72	18	18	72	120
59	10202052	20*52	20	20	52	100
60	10202062	20*62	20	20	62	110
61	10202072	20*72	20	20	72	120



平底尖刀

Solid Carbide Flat Bottom Engraving Bit

1022

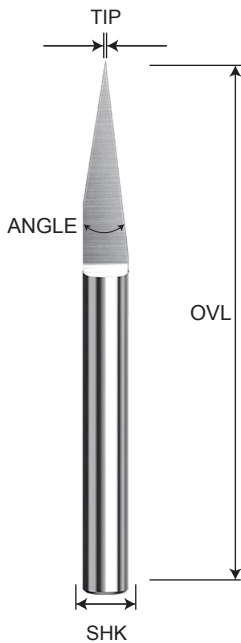

序号	编号	柄径	角度	刀尖	总长
NO	Order No.	SHK	ANGLE	TIP	OVL
1	102231A10	3.175	10	0.1/0.2/0.3	33
2	102231A15	3.175	15	0.1/0.2/0.3	33
3	102231A20	3.175	20	0.1/0.2/0.3/0.4/0.5/0.8/1.0	33
4	102231A30	3.175	30	0.1/0.2/0.3/0.4/0.5/0.8/1.0	33
5	102231A45	3.175	45	0.1/0.2/0.3/0.4/0.5	33
6	102231A60	3.175	60	0.1/0.2/0.3/0.4/0.5	33
7	102231A90	3.175	90	0.1/0.2/0.3/0.4/0.5	33
8	102204A20	4	20	0.1/0.2/0.3/0.4/0.5/0.8/1.0	45
9	102204A30	4	30	0.1/0.2/0.3/0.4/0.5/0.8/1.0	45
10	102204A45	4	45	0.1/0.2/0.3/0.4/0.5/0.8/1.0	45

硬质合金CNC铣刀

PCB钻头与铣刀

合金木工钻头

合金花型刀

高速钢CNC铣刀
与钻头

金刚石&合金锯片

高速钢与合金套式
木工刀片

CNC机床配件

平底尖刀

Solid Carbide Flat Bottom Engraving Bit

1022

序号	编号	柄径	角度	刀尖	总长
NO	Order No.	SHK	ANGLE	TIP	OVL
11	102204A60	4	60	0.1/0.2/0.3/0.4/0.5/0.8/1.0	45
12	102204A90	4	90	0.1/0.2/0.3/0.4/0.5/0.8/1.0	45
13	102206A20	6	20	0.1/0.2/0.3/0.4/0.5/0.8/1.0/2.0	50
14	102206A30	6	30	0.1/0.2/0.3/0.4/0.5/0.8/1.0/2.0	50
15	102206A45	6	45	0.1/0.2/0.3/0.4/0.5/0.8/1.0/2.0	50
16	102206A60	6	60	0.1/0.2/0.3/0.4/0.5/0.8/1.0/2.0	50
17	102206A90	6	90	0.1/0.2/0.3/0.4/0.5/0.8/1.0/2.0	50

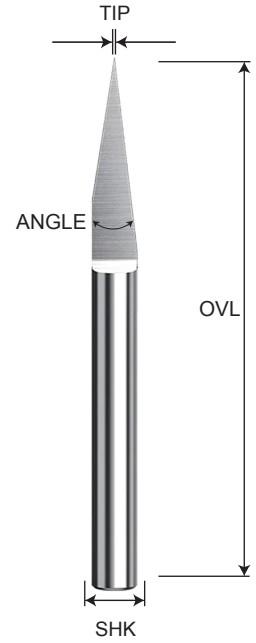

三棱尖刀

Solid Carbide Three Edge Engraving Bit

1024

序号	编号	关键尺寸	柄径	角度	刀尖	总长
NO	Order No.	Size	SHK	ANGLE	TIP	OVL
1	10241533	T0.1*15°3.175	3.175	15	0.1	33
2	10242033	T0.1*20°3.175	3.175	20	0.1	33
3	10243033	T0.1*30°3.175	3.175	30	0.1	33
4	10244533	T0.1*45°3.175	3.175	45	0.1	33
5	10246033	T0.1*60°3.175	3.175	60	0.1	33
6	10249033	T0.1*90°3.175	3.175	90	0.1	33
7	10241538	T0.1*15°3.175	3.175	15	0.1	38
8	10242038	T0.1*20°3.175	3.175	20	0.1	38
9	10243038	T0.1*30°3.175	3.175	30	0.1	38
10	10244538	T0.1*45°3.175	3.175	45	0.1	38
11	10246038	T0.1*60°3.175	3.175	60	0.1	38
12	10249038	T0.1*90°3.175	3.175	90	0.1	38
13	10242045	T0.1*20°4	4	20	0.1	45
14	10243045	T0.1*30°4	4	30	0.1	45
15	10244545	T0.1*45°4	4	45	0.1	45
16	10246045	T0.1*60°4	4	60	0.1	45
17	10249045	T0.1*90°4	4	90	0.1	45
18	10243050	T0.1*30°6	6	30	0.1	50
19	10244550	T0.1*45°6	6	45	0.1	50
20	10246050	T0.1*60°6	6	60	0.1	50
21	10249050	T0.1*90°6	6	90	0.1	50

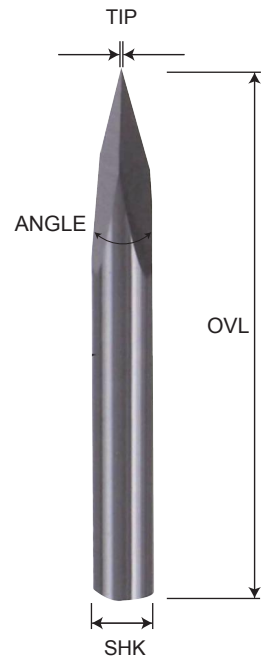

硬质合金CNC铣刀

PCB钻头与铣刀

合金木工钻头

合金花型刀

与钻头
高速钢CNC铣刀

金刚石及合金锯片

木工刀片
高速钢与合金套式

CNC机床配件

硬质合金CNC铣刀

PCB钻头与铣刀

合金木工钻头

合金花型刀

高速钢CNC铣刀
与钻头

金刚石及合金薄片

高速钢与合金套式
木工刀片

CNC机床配件

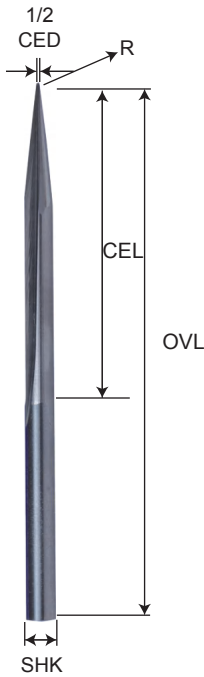

二刃直槽球头尖刀

Solid Carbide Ball Nose Straight Slot Engraving Bit

1079

序号	编号	关键尺寸	柄径	球头半径	刃长	总长
NO	Order No.	Size	SHK	1/2 R	CEL	OVL
1	10790525	R0.5*25	6	0.5	25	60
2	10797525	R0.75*25	6	0.75	25	60
3	10791025	R1*25	6	1	25	60
4	10791525	R1.5*25	6	1.5	25	60
5	10792025	R2*25	6	2	25	60
6	10790530	R0.5*30	6	0.5	30	70
7	10797530	R0.75*30	6	0.75	30	70
8	10791030	R1*30	6	1	30	70
9	10791530	R1.5*30	6	1.5	30	70
10	10792030	R2*30	6	2	30	70
11	10790535	R0.5*35	6	0.5	35	80
12	10797535	R0.75*35	6	0.75	35	80
13	10791035	R1*35	6	1	35	80
14	10791535	R1.5*35	6	1.5	35	80
15	10792035	R2*35	6	2	35	80
16	10790545	R0.5*45	6	0.5	45	100
17	10797545	R0.75*45	6	0.75	45	100
18	10791045	R1*45	6	1	45	100
19	10791545	R1.5*45	6	1.5	45	100
20	10792045	R2*45	6	2	45	100

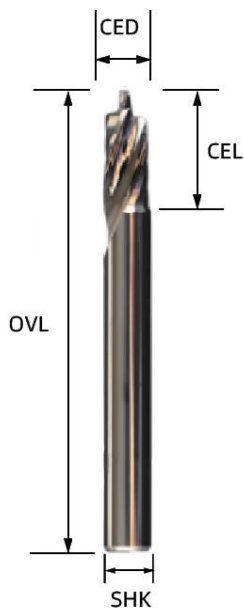

无边刻字刀

Solid Carbide Step Endless Engraving Bit

1301

序号	编号	关键尺寸	刃径	刃长	柄径	总长
NO	Order No.	SIZE	CED	CEL	SHK	OVL
1	13013115	1.5*1.5*3.175	1.5	2	3.175	38.5
2	13010415	1.5*1.5*4	1.5	2	4	45

霓虹灯亚克力灯管专用铣刀

Solid Carbide Led Neon Signmaking End Mill

1302

序号	编号	关键尺寸	小径	最大刃径	柄径	总长	下刀深	胶条
NO.	Order No.	Size	d1	d2	D	OVL	H	Neon Width
1	13026425	6*4.2*10*50	6	8	10	50	4.2	6
2	13026550	6*5.8*10*50	6	8	10	50	5.8	6
3	13028450	8*4.2*10*50	8	10	10	50	4.2	8
4	13028550	8*5.8*10*50	8	10	10	50	5.8	8
5	13021015	10*4.2*12*50	10	12	12	50	4.2	12
6	13021055	10*5.8*12*50	10	12	12	50	5.8	12

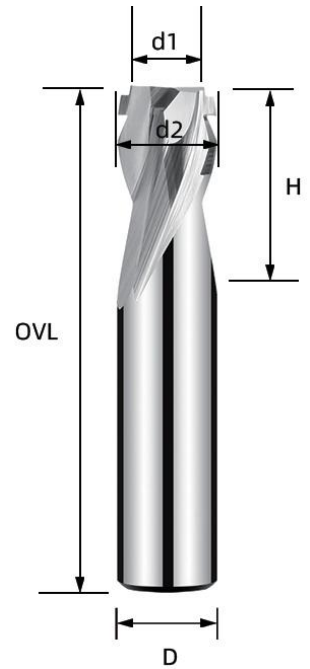

硬质合金CNC铣刀

PCB钻头与铣刀

合金木工钻头

合金花型刀

与钻头
高速钢CNC铣刀

金刚石&合金锯片

木工刀片
高速钢与合金套式

CNC机床配件

TCT二刃木工直刀 TCT Two Flutes Straight Bit

1081

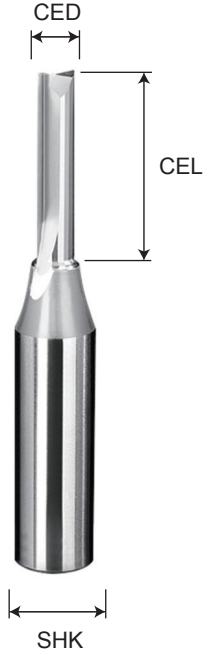

序号	编号	关键尺寸	柄径	刃径	刃长
NO	Order No.	Size	SHK	CED	CEL
1	10810205	2*5	1/2	2	5
2	10812508	2.5*8	1/2	2.5	8
3	10810310	3*10	1/2	3	10
4	10810312	3*12	1/2	3	12
5	10810315	3*15	1/2	3	15
6	10813118	3.175*18	1/2	3.175	18
7	10813120	3.175*20	1/2	3.175	20
8	10813508	3.5*8	1/2	3.5	8
9	10813510	3.5*10	1/2	3.5	10
10	10813512	3.5*12	1/2	3.5	12
11	10813515	3.5*15	1/2	3.5	15
12	10813518	3.5*18	1/2	3.5	18
13	10813520	3.5*20	1/2	3.5	20
14	10810410	4*10	1/2	4	10
15	10810412	4*12	1/2	4	12
16	10810415	4*15	1/2	4	15
17	10810420	4*20	1/2	4	20
18	10810422	4*22	1/2	4	22
19	10810425	4*25	1/2	4	25
20	10810426	4*26	1/2	4	26
21	10810428	4*28	1/2	4	28
22	10814520	4.5*20	1/2	4.5	20
23	10814528	4.5*28	1/2	4.5	28
24	10810512	5*12	1/2	5	12
25	10810515	5*15	1/2	5	15
26	10810518	5*18	1/2	5	18
27	10810520	5*20	1/2	5	20
28	10810522	5*22	1/2	5	22
29	10810525	5*25	1/2	5	25
30	10810528	5*28	1/2	5	28
31	10810530	5*30	1/2	5	30
32	10815512	5.5*12	1/2	5.5	12
33	10815515	5.5*15	1/2	5.5	15
34	10815520	5.5*20	1/2	5.5	20
35	10815522	5.5*22	1/2	5.5	22
36	10810615	6*15	1/2	6	15
37	10810618	6*18	1/2	6	18
38	10810620	6*20	1/2	6	20
39	10810622	6*22	1/2	6	22
40	10810625	6*25	1/2	6	25

硬质合金CNC铣刀

PCB钻头与铣刀

合金木工钻头

合金花型刀

高速钢CNC铣刀
与钻头

金刚石&合金锯片

高速钢与合金套弄式
木工刀片

CNC机床配件

TCT二刃木工直刀

TCT Two Flutes Straight Bit

1081

序号	编号	关键尺寸	柄径	刃径	刃长
NO	Order No.	Size	SHK	CED	CEL
41	10810626	6*26	1/2	6	26
42	10810628	6*28	1/2	6	28
43	10810630	6*30	1/2	6	30
44	10810632	6*32	1/2	6	32
45	10810640	6*40	1/2	6	40
46	10810645	6*45	1/2	6	45
47	10810720	7*20	1/2	7	20
48	10810722	7*22	1/2	7	22
49	10810725	7*25	1/2	7	25
50	10810728	7*28	1/2	7	28
51	10810730	7*30	1/2	7	30
52	10810820	8*20	1/2	8	20
53	10810822	8*22	1/2	8	22
54	10810825	8*25	1/2	8	25
55	10810828	8*28	1/2	8	28
56	10810830	8*30	1/2	8	30
57	10810832	8*32	1/2	8	32
58	10810835	8*35	1/2	8	35
59	10810840	8*40	1/2	8	40
60	10810845	8*45	1/2	8	45
61	10810850	8*50	1/2	8	50
62	10810855	8*55	1/2	8	55
63	10811020	10*20	1/2	10	20
64	10811025	10*25	1/2	10	25
65	10811030	10*30	1/2	10	30
66	10811035	10*35	1/2	10	35
67	10811040	10*40	1/2	10	40
68	10811050	10*50	1/2	10	50
69	10811230	12*30	1/2	12	30
70	10811235	12*35	1/2	12	35
71	10811240	12*40	1/2	12	40
72	10811245	12*45	1/2	12	45
73	10811250	12*50	1/2	12	50

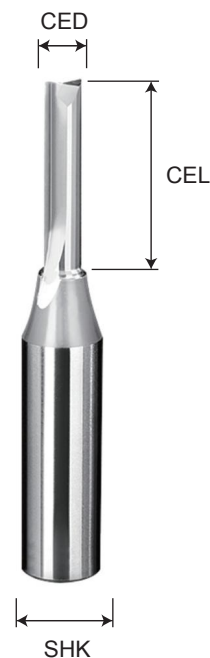

硬质合金CNC铣刀

PCB钻头与铣刀

合金木工钻头

合金花型刀

与钻头
高速钢CNC铣刀

金刚石 & 合金锯片

木工刀片
高速钢与合金套式

CNC机床配件



TCT三刃开料刀

TCT Three Flutes Straight Bit With Teeth

1080

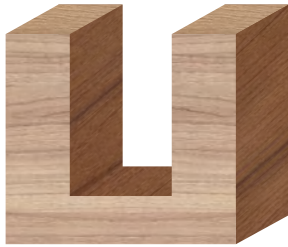
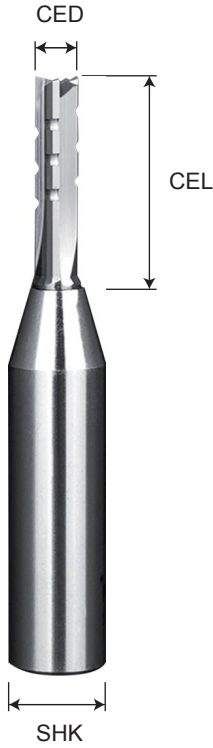

序号	编号	关键尺寸	柄径	刃径	刃长
NO	Order No.	Size	SHK	CED	CEL
1	10800615	6*15	1/2	6	15
2	10800618	6*18	1/2	6	18
3	10800620	6*20	1/2	6	20
4	10800622	6*22	1/2	6	22
5	10800625	6*25	1/2	6	25
6	10800626	6*26	1/2	6	26
7	10800628	6*28	1/2	6	28
8	10800630	6*30	1/2	6	30
9	10800632	6*32	1/2	6	32
10	10800635	6*35	1/2	6	35
11	10800640	6*40	1/2	6	40
12	10800720	7*20	1/2	7	20
13	10800722	7*22	1/2	7	22
14	10800725	7*25	1/2	7	25
15	10800728	7*28	1/2	7	28
16	10800730	7*30	1/2	7	30
17	10800820	8*20	1/2	8	20
18	10800822	8*22	1/2	8	22
19	10800825	8*25	1/2	8	25
20	10800828	8*28	1/2	8	28
21	10800830	8*30	1/2	8	30
22	10800832	8*32	1/2	8	32
23	10800835	8*35	1/2	8	35
24	10800838	8*38	1/2	8	38
25	10800840	8*40	1/2	8	40
26	10800845	8*45	1/2	8	45
27	10800850	8*50	1/2	8	50
28	10800920	9*20	1/2	9	20
29	10800930	9*30	1/2	9	30
30	10800932	9*32	1/2	9	32
31	10800935	9*35	1/2	9	35
32	10800940	9*40	1/2	9	40
33	10801020	10*20	1/2	10	20
34	10801022	10*22	1/2	10	22
35	10801025	10*25	1/2	10	25
36	10801028	10*28	1/2	10	28
37	10801030	10*30	1/2	10	30
38	10801035	10*35	1/2	10	35
39	10801040	10*40	1/2	10	40
40	10801045	10*45	1/2	10	45

硬质合金CNC铣刀
PCB钻头与铣刀
合金木工钻头
合金花型刀
高速钢CNC铣刀与钻头
金刚石&合金锯片
高速钢与合金舍壳式木工刀片
CNC机床配件

TCT三刃开料刀

TCT Three Flutes Straight Bit With Teeth

1080

序号	编号	关键尺寸	柄径	刃径	刃长
NO	Order No.	Size	SHK	CED	CEL
41	10801050	10*50*1/2	1/2	10	50
42	10801230	12*30*1/2	1/2	12	30
43	10801235	12*35*1/2	1/2	12	35
44	10801240	12*40*1/2	1/2	12	40
45	10801245	12*45*1/2	1/2	12	45
46	10801250	12*50*1/2	1/2	12	50

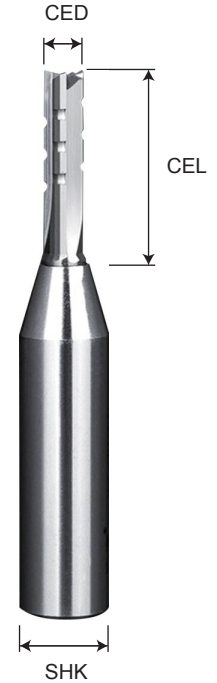

TCT二刃木工螺旋木工刀

TCT Two Flutes Spiral Bit

1087

序号	编号	关键尺寸	柄径	刃径	刃长
NO	Order No.	Size	SHK	CED	CEL
1	10870312	3*12	1/2	3	12
2	10873512	3.5*12	1/2	3.5	12
3	10870412	4*12	1/2	4	12
4	10870415	4*15	1/2	4	15
5	10870420	4*20	1/2	4	20
6	10870428	4*28	1/2	4	28
7	10874515	4.5*15	1/2	4.5	15
8	10870520	5*20	1/2	5	20
9	10875515	5.5*15	1/2	5.5	15
10	10870615	6*15	1/2	6	15
11	10870620	6*20	1/2	6	20
12	10870624	6*24	1/2	6	24
13	10870626	6*26	1/2	6	26
14	10870628	6*28	1/2	6	28
15	10870630	6*30	1/2	6	30
16	10870632	6*32	1/2	6	32
17	10870720	7*20	1/2	7	20
18	10870822	8*22	1/2	8	22
19	10870824	8*24	1/2	8	24

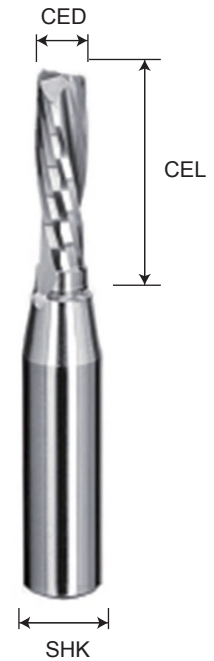

硬质合金CNC铣刀

PCB钻头与铣刀

合金木工钻头

合金花型刀

与钻头
高速钢CNC铣刀

金刚石 & 合金锯片

木工刀片
高速钢与合金合金式

CNC机床配件

硬质合金CNC铣刀

PCB钻头与铣刀

合金木工钻头

合金花型刀

高速钢CNC铣刀
与钻头

金刚石&合金锯片

高速钢与合金套式
木工刀片

CNC机床配件



TCT三刃木工螺旋木工刀 TCT Three Flutes Spiral Bit

1102

序号	编号	关键尺寸	柄径	刃径	刃长
NO	Order No.	Size	SHK	CED	CEL
1	11020615	6*15	1/2	6	15
2	11020620	6*20	1/2	6	20
3	11020624	6*24	1/2	6	24
4	11020626	6*26	1/2	6	26
5	11020628	6*28	1/2	6	28
6	11020630	6*30	1/2	6	30
7	11020632	6*32	1/2	6	32
8	11020720	7*20	1/2	7	20
9	11020822	8*22	1/2	8	22
10	11020824	8*24	1/2	8	24



TCT二刃复合刀带横槽 TCT Two Flutes Compression Bit With Teeth

1103

序号	编号	关键尺寸	柄径	刃径	刃长
NO	Order No.	Size	SHK	CED	CEL
1	11030620	6*20	1/2	6	20
2	11030622	6*22	1/2	6	22
3	11030625	6*25	1/2	6	25
4	11030628	6*28	1/2	6	28
5	11030630	6*30	1/2	6	30
6	11030820	8*20	1/2	8	20
7	11030822	8*22	1/2	8	22
8	11030825	8*25	1/2	8	25
9	11030828	8*28	1/2	8	28
10	11030830	8*30	1/2	8	30
11	11031022	10*22	1/2	10	22
12	11031028	10*28	1/2	10	28
13	11031032	10*32	1/2	10	32

TCT圆底刀

TCT Round Bottom Bit

1104

序号	编号	关键尺寸	柄径	刃径	刃长
NO	Order No.	Size	SHK	CED	CEL
1	1104035/4035	3*5	1/2、1/4	3	5
2	1104047/4047	4*7	1/2、1/4	4	7
3	1104057/4057	5*7	1/2、1/4	5	7
4	1104066/4066	6*6	1/2	6	6
5	11040865/40865	8*6.5	1/2	8	6.5
6	11041805/41805	1/8*5	1/2、1/4	1/8	5
7	11043167/43167	3/16*7	1/2、1/4	3/16	7
8	11041463/41463	1/4*6.35	1/2	1/4	6.35
9	11045168/45168	5/16*8	1/2	5/16	8



TCT榫槽刀

TCT Tenon Mortise Bit

1077

序号	编号	关键尺寸	柄径	刃径	总长	刃数
NO	Order No.	Size	SHK	CED	OVL	Z
1	107706100	4*6	1/2	6	100	4
2	107708100	4*8	1/2	8	100	4
3	107710100	4*10	1/2	10	100	4
4	107712100	4*12	1/2	12	100	4
5	107715100	4*15	1/2	15	100	4
6	107716100	4*16	1/2	16	100	4

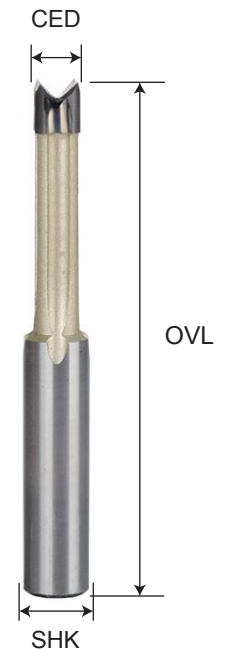

硬质合金CNC铣刀

PCB钻头与铣刀

合金木工钻头

合金花型刀

与钻头

高速钢CNC铣刀

金刚石及合金锯片

木工刀片

高速钢与合金套式

CNC机床配件

PCB 钻头 PCB Drill Bit

1014

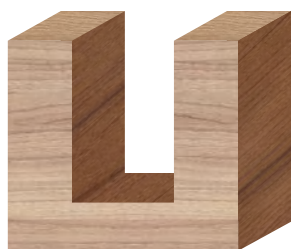
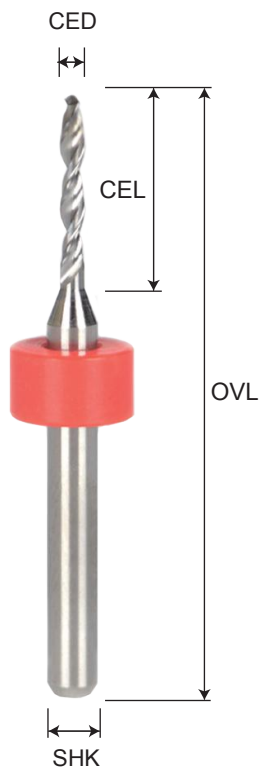

序号 No	编号 Order No.	关键尺寸 Size	柄径 SHK	刃径 CED	刃长 CEL	全长 OVL
1	10140205	0.2*5	3.175	0.2	5	38
2	101402505	0.25*5	3.175	0.25	5	38
3	10140355	0.3*5.5	3.175	0.3	5.5	38
4	101403555	0.35*5.5	3.175	0.35	5.5	38
5	10140407	0.4*7	3.175	0.4	7	38
6	101404507	0.45*7	3.175	0.45	7	38
7	10140585	0.5*8.5	3.175	0.5	8.5	38
8	101405585	0.55*8.5	3.175	0.55	8.5	38
9	10140695	0.6*9.5	3.175	0.6	9.5	38
10	101406895	0.65*9.5	3.175	0.65	9.5	38
11	10140795	0.7*9.5	3.175	0.7	9.5	38
12	101407595	0.75*9.5	3.175	0.75	9.5	38
13	10140895	0.8*9.5	3.175	0.8	9.5	38
14	101408595	0.85*9.5	3.175	0.85	9.5	38
15	10140995	0.9*9.5	3.175	0.9	9.5	38
16	101409595	0.95*9.5	3.175	0.95	9.5	38
17	101410105	1.0*10.5	3.175	1	10.5	38
18	101410510	1.05*10.5	3.175	1.05	10.5	38
19	101411105	1.1*10.5	3.175	1.1	10.5	38
20	101411510	1.15*10.5	3.175	1.15	10.5	38
21	101412105	1.2*10.5	3.175	1.2	10.5	38
22	101412510	1.25*10.5	3.175	1.25	10.5	38
23	1014130	1.3*12	3.175	1.3	12	38
24	1014135	1.35*12	3.175	1.35	12	38
25	1014140	1.4*12	3.175	1.4	12	38
26	1014145	1.45*12	3.175	1.45	12	38
27	1014150	1.5*12	3.175	1.5	12	38
28	1014155	1.55*12	3.175	1.55	12	38
29	1014160	1.6*12	3.175	1.6	12	38
30	1014165	1.65*12	3.175	1.65	12	38
31	1014170	1.7*12	3.175	1.7	12	38
32	1014175	1.75*12	3.175	1.75	12	38
33	1014180	1.8*12	3.175	1.8	12	38
34	1014185	1.85*12	3.175	1.85	12	38
35	1014190	1.9*12	3.175	1.9	12	38
36	1014195	1.95*12	3.175	1.95	12	38
37	1014020	2*12	3.175	2	12	38
38	1014205	2.05*12	3.175	2.05	12	38
39	1014210	2.1*12	3.175	2.1	12	38
40	1014215	2.15*12	3.175	2.15	12	38

硬质合金CNC铣刀

PCB钻头与铣刀

合金木工钻头

合金花型刀

高速钢CNC铣刀
与钻头

金刚石&合金锯片

高速钢与合金舍斧式
木工刀片

CNC机床配件

PCB 钻头 PCB Drill Bit

1014

序号	编号	产品规格	柄径	刃径	刃长	总长
NO	Order No.	Specification	SHK	CED	CEL	OVL
41	1014220	2.2*12	3.175	2.2	12	38.5
42	1014225	2.25*12	3.175	2.25	12	38.5
43	1014230	2.3*12	3.175	2.3	12	38.5
44	1014235	2.35*12	3.175	2.35	12	38.5
45	1014240	2.4*12	3.175	2.4	12	38.5
46	1014245	2.45*12	3.175	2.45	12	38.5
47	1014250	2.5*12	3.175	2.5	12	38.5
48	1014255	2.55*12	3.175	2.55	12	38.5
49	1014260	2.6*12	3.175	2.6	12	38.5
50	1014265	2.65*12	3.175	2.65	12	38.5
51	1014270	2.7*12	3.175	2.7	12	38.5
52	1014275	2.75*12	3.175	2.75	12	38.5
53	1014280	2.8*12	3.175	2.8	12	38.5
54	1014285	2.85*12	3.175	2.85	12	38.5
55	1014290	2.9*12	3.175	2.9	12	38.5
56	1014295	2.95*12	3.175	2.95	12	38.5
57	1014030	3*12	3.175	3	12	38.5
58	1014305	3.05*12	3.175	3.05	12	38.5
59	1014317	3.175*12	3.175	3.175	12	38.5
60	1014110PCS	0.3-1.2	0.3/0.4/0.5/0.6/0.7/0.8/0.9/1.0/1.1/1.2			
61	1014210PCS	1.1-2.0	1.1/1.2/1.3/1.4/1.5/1.6/1.7/1.8/1.9/2.0			
62	1014310PCS	2.1-3.0	2.1/2.2/2.3/2.4/2.5/2.6/2.7/2.8/2.9/3.0			

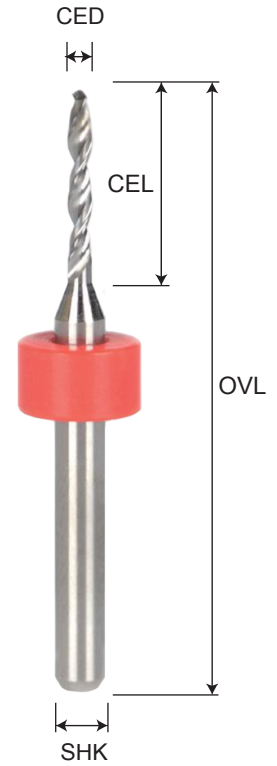

硬质合金CNC铣刀

PCB钻头与铣刀

合金木工钻头

合金花型刀

与钻头
高速钢CNC铣刀

金刚石&合金锯片

木工刀片
高速钢与合金斧斧式

CNC机床配件

硬质合金CNC铣刀

PCB钻头与铣刀

合金木工钻头

合金扩型刀

与钻头
高速钢CNC铣刀

金刚石&合金锯片

高速钢与合金舍弃式
木工刀片

CNC机床配件

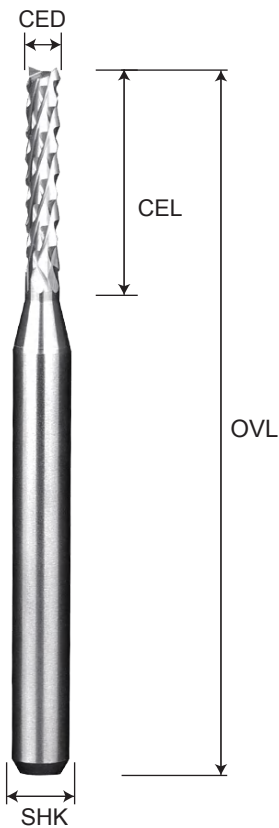

PCB铣刀 PCB End Mill

1012

序号 No	编号 Order No.	关键尺寸 Size	柄径 SHK	刃径 CED	刃长 CEL	全长 OVL
1	1012005	0.5*5	3.175	0.5	5	38
2	1012006	0.6*5	3.175	0.6	5	38
3	1012007	0.7*4	3.175	0.7	4	38
4	1012008	0.8*5.5	3.175	0.8	5.5	38
5	1012009	0.9*6	3.175	0.9	6	38
6	1012010	1.0*7	3.175	1	7	38
7	1012011	1.1*7	3.175	1.1	7	38
8	1012012	1.2*7	3.175	1.2	7	38
9	1012013	1.3*7.5	3.175	1.3	7.5	38
10	1012014	1.4*7.5	3.175	1.4	7.5	38
11	1012015	1.5*8.5	3.175	1.5	8.5	38
12	1012016	1.6*8.5	3.175	1.6	8.5	38
13	1012017	1.7*9.5	3.175	1.7	9.5	38
14	1012018	1.8*9.5	3.175	1.8	9.5	38
15	1012019	1.9*9.5	3.175	1.9	9.5	38
16	1012020	2.0*9.5	3.175	2	9.5	38
17	1012021	2.1*10.5	3.175	2.1	10.5	38
18	1012024	2.4*10.5	3.175	2.4	10.5	38
19	1012025	2.5*10.5	3.175	2.5	10.5	38
20	1012030	3.0*12	3.175	3	12	38
21	10123112	3.175*12	3.175	3.175	12	38
22	10123115	3.175*15	3.175	3.175	15	38
23	10123117	3.175*17	3.175	3.175	17	38
24	10123122	3.175*22	3.175	3.175	22	38
25	10123125	3.175*25	3.175	3.175	25	38
26	1012110pcs	0.8-3.0	0.8/1.0/1.2/1.4/1.6/1.8/2.0/2.2/2.4/3.0			
27	1012210pcs	0.8-3.175	0.8/1.0/1.2/1.4/1.6/1.8/2.0/2.2/2.4/3.175			
28	1012310pcs	0.8-3.0	0.8/1.0/1.2/1.4/1.6/1.8/2.0/2.2/2.4/3.0			
29	1012410pcs	0.8-3.175	0.8/1.0/1.2/1.4/1.6/1.8/2.0/2.2/2.4/3.175			





经济型合金排钻

Carbide Tipped Dowel Boring Bit

1068

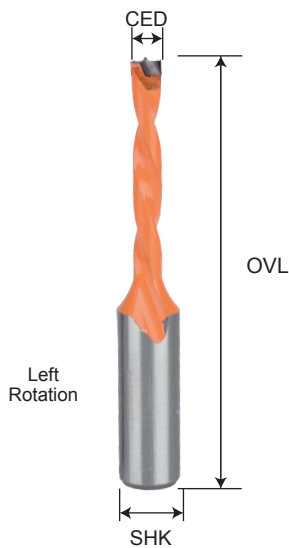
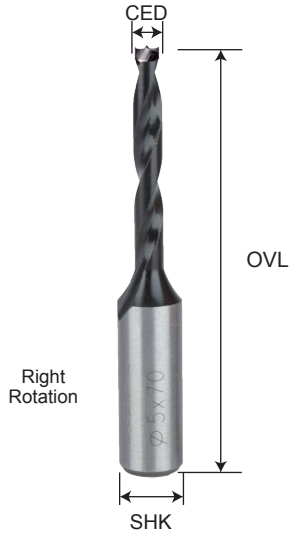

序号 No	编号 Code		关键尺寸 Size	柄径 SHK	刃径 CED	全长 OVL
	左旋 Left Rotation	右旋 Right Rotation				
1	10680457L	10680457R	4*57	10	4	57
2	10684557L	10684557R	4.5*57	10	4.5	57
3	10680557L	10680557R	5*57	10	5	57
4	10685557L	10685557R	5.5*57	10	5.5	57
5	10680657L	10680657R	6*57	10	6	57
6	10686557L	10686557R	6.5*57	10	6.5	57
7	10680757L	10680757R	7*57	10	7	57
8	10687557L	10687557R	7.5*57	10	7.5	57
9	10680857L	10680857R	8*57	10	8	57
10	10688557L	10688557R	8.5*57	10	8.5	57
11	10680957L	10680957R	9*57	10	9	57
12	10689557L	10689557R	9.5*57	10	9.5	57
13	10681057L	10681057R	10*57	10	10	57
14	106810557L	106810557R	10.5*57	10	10.5	57
15	10681157L	10681157R	11*57	10	11	57
16	106811557L	106811557R	11.5*57	10	11.5	57
17	10681257L	10681257R	12*57	10	12	57
18	10681357L	10681357R	13*57	10	13	57
19	10681457L	10681457R	14*57	10	14	57
20	10681557L	10681557R	15*57	10	15	57
21	10680470L	10680470R	4*70	10	4	70
22	10684570L	10684570R	4.5*70	10	4.5	70
23	10680570L	10680570R	5*70	10	5	70
24	10685570L	10685570R	5.5*70	10	5.5	70
25	10680670L	10680670R	6*70	10	6	70
26	10686570L	10686570R	6.5*70	10	6.5	70
27	10680770L	10680770R	7*70	10	7	70
28	10687570L	10687570R	7.5*70	10	7.5	70
29	10680870L	10680870R	8*70	10	8	70
30	10688570L	10688570R	8.5*70	10	8.5	70
31	10680970L	10680970R	9*70	10	9	70
32	10689570L	10689570R	9.5*70	10	9.5	70
33	10681070L	10681070R	10*70	10	10	70
34	106810570L	106810570R	10.5*70	10	10.5	70
35	10681170L	10681170R	11*70	10	11	70
36	106811570L	106811570R	11.5*70	10	11.5	70
37	10681270L	10681270R	12*70	10	12	70
38	10681370L	10681370R	13*70	10	13	70
39	10681470L	10681470R	14*70	10	14	70
40	10681570L	10681570R	15*70	10	15	70

硬质合金CNC铣刀

PCB钻头与铣刀

合金木工钻头

合金成型刀

高速钢CNC铣刀
与钻头

金刚石及合金锯片

高速钢与合金舍壳式
木工刀片

CNC机床配件

高性能型合金排钻

Carbide Tipped High Performance Dowel Boring Bit

1066

序号 NO	编号 Code		柄径 SHK	刃径 CED	全长 OVL
	左旋 Left Rotation	右旋 Right Rotation			
1	10660457L	10660457R	10	4	57
2	10664557L	10664557R	10	4.5	57
3	10660557L	10660557R	10	5	57
4	10665557L	10665557R	10	5.5	57
5	10660657L	10660657R	10	6	57
6	10666557L	10666557R	10	6.5	57
7	10660757L	10660757R	10	7	57
8	10667557L	10667557R	10	7.5	57
9	10660857L	10660857R	10	8	57
10	10668557L	10668557R	10	8.5	57
11	10660957L	10660957R	10	9	57
12	10669557L	10669557R	10	9.5	57
13	10661057L	10661057R	10	10	57
14	106610557L	106610557R	10	10.5	57
15	10661157L	10661157R	10	11	57
16	106611557L	106611557R	10	11.5	57
17	10661257L	10661257R	10	12	57
18	10661357L	10661357R	10	13	57
19	10661457L	10661457R	10	14	57
20	10661557L	10661557R	10	15	57
21	10660470L	10660470R	10	4	70
22	10664570L	10664570R	10	4.5	70
23	10660570L	10660570R	10	5	70
24	10665570L	10665570R	10	5.5	70
25	10660670L	10660670R	10	6	70
26	10666570L	10666570R	10	6.5	70
27	10660770L	10660770R	10	7	70
28	10667570L	10667570R	10	7.5	70
29	10660870L	10660870R	10	8	70
30	10668570L	10668570R	10	8.5	70
31	10660970L	10660970R	10	9	70
32	10669570L	10669570R	10	9.5	70
33	10661070L	10661070R	10	10	70
34	106610570L	106610570R	10	10.5	70
35	10661170L	10661170R	10	11	70
36	106611570L	106611570R	10	11.5	70
37	10661270L	10661270R	10	12	70
38	10661370L	10661370R	10	13	70
39	10661470L	10661470R	10	14	70
40	10661570L	10661570R	10	15	70

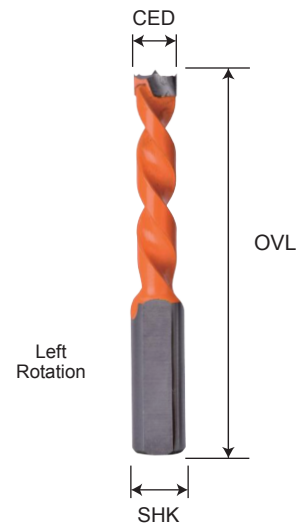
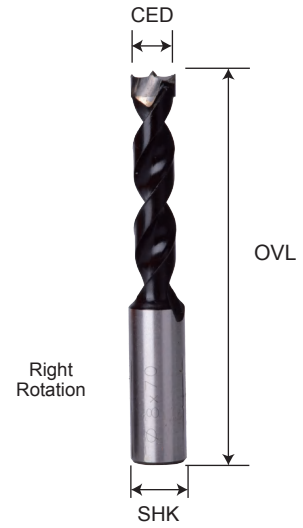

硬质合金CNC铣刀

PCB钻头合金铣刀

合金木工钻头

合金花型刀

与钻头

高速钢CNC铣刀

金刚石及合金锯片

木工刀片

高速钢与合金套钻式

CNC机床配件



加长型经济合金排钻

Carbide Tipped Extended Dowel Boring Bit

1067

硬质合金CNC铣刀
PCB钻头与铣刀
合金车工钻头
合金花型刀
高速钢CNC铣刀
金刚石&合金锯片
高速钢与合金套式木工刀片
CNC机床配件

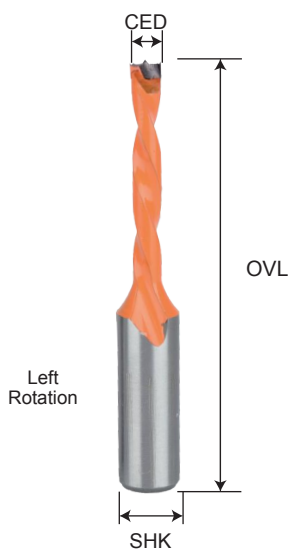

序号	编号 Code		柄径 SHK	刃径 CED	全长 OVL
NO	左旋 Left Rotation	右旋 Right Rotation			
1	10670580L	10670580R	10	5	80
2	10670680L	10670680R	10	6	80
3	10670780L	10670780R	10	7	80
4	10670880L	10670880R	10	8	80
5	10670980L	10670980R	10	9	80
6	10671080L	10671080R	10	10	80
7	10671180L	10671180R	10	11	80
8	10671280L	10671280R	10	12	80
9	10671380L	10671380R	10	13	80
10	10671480L	10671480R	10	14	80
11	10671580L	10671580R	10	15	80
12	10670590L	10670590R	10	5	90
13	10670690L	10670690R	10	6	90
14	10670790L	10670790R	10	7	90
15	10670890L	10670890R	10	8	90
16	10670990L	10670990R	10	9	90
17	10671090L	10671090R	10	10	90
18	10671190L	10671190R	10	11	90
19	10671290L	10671290R	10	12	90
20	10671390L	10671390R	10	13	90
21	10671490L	10671490R	10	14	90
22	10671590L	10671590R	10	15	90
23	106705100L	106705100R	10	5	100
24	106706100L	106706100R	10	6	100
25	106707100L	106707100R	10	7	100
26	106708100L	106708100R	10	8	100
27	106709100L	106709100R	10	9	100
28	106710100L	106710100R	10	10	100
29	106711100L	106711100R	10	11	100
30	106712100L	106712100R	10	12	100
31	106713100L	106713100R	10	13	100
32	106714100L	106714100R	10	14	100
33	106715100L	106715100R	10	15	100

经济型通孔钻

Carbide Tipped Through-hole Boring Bit

1107

序号 No	编号 Code		关键尺寸 Size	柄径 SHK	刃径 CED	全长 OVL
	左旋 Left Rotation	右旋 Right Rotation				
1	11070557L	11070557R	5*57	10	5	57
2	11070657L	11070657R	6*57	10	6	57
3	11070757L	11070757R	7*57	10	7	57
4	11070857L	11070857R	8*57	10	8	57
5	11070957L	11070957R	9*57	10	9	57
6	11071057L	11071057R	10*57	10	10	57
7	11071257L	11071257R	12*57	10	12	57
8	11071557L	11071557R	15*57	10	15	57
9	11070570L	11070570R	5*70	10	5	70
10	11070670L	11070670R	6*70	10	6	70
11	11070770L	11070770R	7*70	10	7	70
12	11070870L	11070870R	8*70	10	8	70
13	11070970L	11070970R	9*70	10	9	70
14	11071070L	11071070R	10*70	10	10	70
15	11071270L	11071270R	12*70	10	12	70
16	11071570L	11071570R	15*70	10	15	70

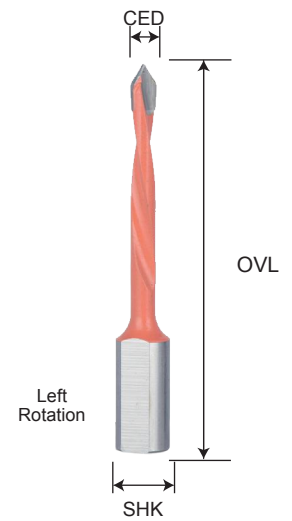
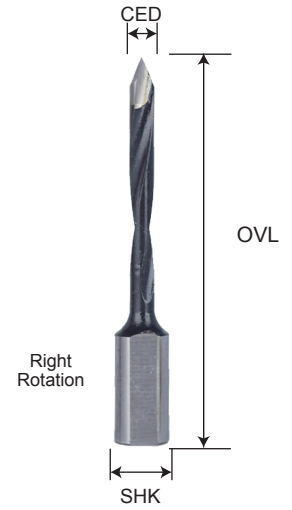

硬质合金CNC铣刀

PCB钻头与铣刀

合金木工钻头

合金花型刀

与钻头

高速钢CNC铣刀

金刚石&合金锯片

木工刀片

高速钢与合金套式

CNC机床配件

合金中心钻

Carbide Tipped Centre Boring Bit

1060

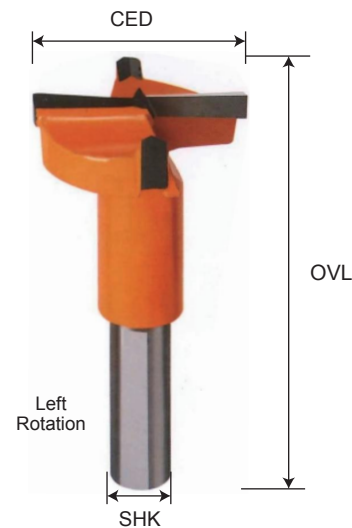
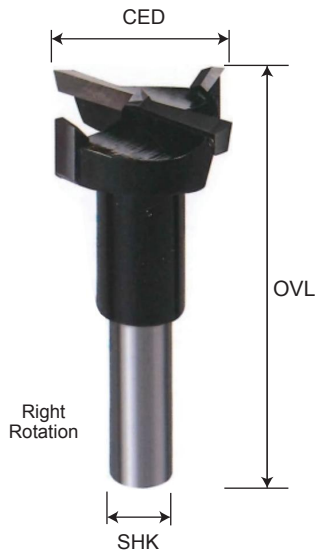

序号 No	编号 Code		关键尺寸 Size	柄径 SHK	刃径 CED	全长 OVL
	左旋 Left Rotation	右旋 Right Rotation				
1	10601557L	10601557R	10*15	10	15	57
2	10601657L	10601657R	10*16	10	16	57
3	10601757L	10601757R	10*17	10	17	57
4	10601857L	10601857R	10*18	10	18	57
5	10601957L	10601957R	10*19	10	19	57
6	10602057L	10602057R	10*20	10	20	57
7	10602157L	10602157R	10*21	10	21	57
8	10602257L	10602257R	10*22	10	22	57
9	10602357L	10602357R	10*23	10	23	57
10	10602457L	10602457R	10*24	10	24	57
11	10602557L	10602557R	10*25	10	25	57
12	10602657L	10602657R	10*26	10	26	57
13	10602757L	10602757R	10*27	10	27	57
14	10602857L	10602857R	10*28	10	28	57
15	10602957L	10602957R	10*29	10	29	57
16	10603057L	10603057R	10*30	10	30	57
17	10603157L	10603157R	10*31	10	31	57
18	10603257L	10603257R	10*32	10	32	57
19	10603357L	10603357R	10*33	10	33	57
20	10603457L	10603457R	10*34	10	34	57
21	10603557L	10603557R	10*35	10	35	57
22	10603657L	10603657R	10*36	10	36	57
23	10603757L	10603757R	10*37	10	37	57
24	10603857L	10603857R	10*38	10	38	57
25	10603957L	10603957R	10*39	10	39	57
26	10604057L	10604057R	10*40	10	40	57
27	10605057L	10605057R	10*50	10	50	57
28	10605357L	10605357R	10*53	10	53	57
29	10605557L	10605557R	10*55	10	55	57
30	10606057L	10606057R	10*60	10	60	57
31	10606557L	10606557R	10*65	10	65	57
32	10607057L	10607057R	10*70	10	70	57
33	10608057L	10608057R	10*80	10	80	57
34	10601670L	10601670R	10*16	10	16	70
35	10601770L	10601770R	10*17	10	17	70
36	10601870L	10601870R	10*18	10	18	70
37	10601970L	10601970R	10*19	10	19	70
38	10602070L	10602070R	10*20	10	20	70
39	10602170L	10602170R	10*21	10	21	70
40	10602270L	10602270R	10*22	10	22	70

硬质合金CNC铣刀

PCB钻头与铣刀

合金车工钻头

合金花型刀

高速钢CNC铣刀
与钻头

金刚石&合金锯片

高速钢与合金套式
木工刀片

CNC机床配件

合金中心钻

Carbide Tipped Centre Boring Bit

1060

序号 No	编号 Code		关键尺寸 Size	柄径 SHK	刃径 CED	全长 OVL
	左旋 Left Rotation	右旋 Right Rotation				
41	10602370L	10602370R	10*23	10	23	70
42	10602470L	10602470R	10*24	10	24	70
43	10602570L	10602570R	10*25	10	25	70
44	10602670L	10602670R	10*26	10	26	70
45	10602770L	10602770R	10*27	10	27	70
46	10602870L	10602870R	10*28	10	28	70
47	10602970L	10602970R	10*29	10	29	70
48	10603070L	10603070R	10*30	10	30	70
49	10603170L	10603170R	10*31	10	31	70
50	10603270L	10603270R	10*32	10	32	70
51	10603370L	10603370R	10*33	10	33	70
52	10603470L	10603470R	10*34	10	34	70
53	10603570L	10603570R	10*35	10	35	70
54	10603670L	10603670R	10*36	10	36	70
55	10603770L	10603770R	10*37	10	37	70
56	10603870L	10603870R	10*38	10	38	70
57	10603970L	10603970R	10*39	10	39	70
58	10604070L	10604070R	10*40	10	40	70
59	10605070L	10605070R	10*50	10	50	70
60	10605370L	10605370R	10*53	10	53	70
61	10605570L	10605570R	10*55	10	55	70
62	10606070L	10606070R	10*60	10	60	70
63	10606570L	10606570R	10*65	10	65	70
64	10607070L	10607070R	10*70	10	70	70
65	10608070L	10608070R	10*80	10	80	70

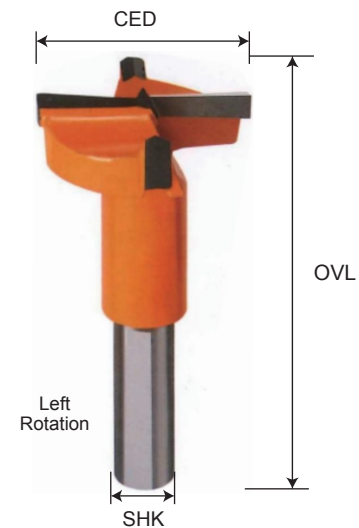
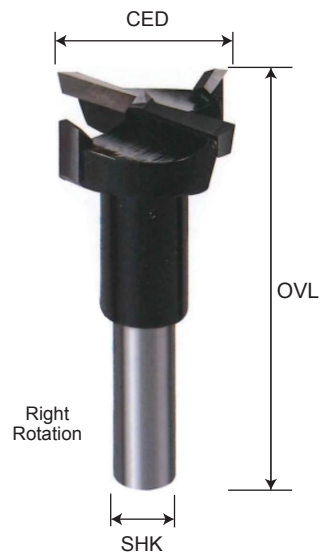

硬质合金CNC铣刀

PCB钻头与铣刀

合金木工钻头

合金花型刀

与钻头

高速钢CNC铣刀

金刚石及合金锯片

木工刀片

高速钢与合金合金式

CNC机床配件

合金皇冠钻

Carbide Tipped Type B Dowel Boring Bit

1109

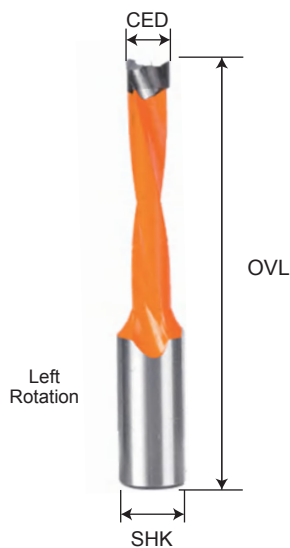

序号 No	编号 Code		关键尺寸 Size	柄径 SHK	刃径 CED	全长 OVL
	左旋 Left Rotation	右旋 Right Rotation				
1	11090457L	11090457R	4*57	10	4	57
2	11090557L	11090557R	5*57	10	5	57
3	11090657L	11090657R	6*57	10	6	57
4	11090757L	11090757R	7*57	10	7	57
5	11090857L	11090857R	8*57	10	8	57
6	11090957L	11090957R	9*57	10	9	57
7	11091057L	11091057R	10*57	10	10	57
8	11091157L	11091157R	11*57	10	11	57
9	11091257L	11091257R	12*57	10	12	57
10	11091357L	11091357R	13*57	10	13	57
11	11091457L	11091457R	14*57	10	14	57
12	11091557L	11091557R	15*57	10	15	57
13	11090470L	11090470R	4*70	10	4	70
14	11090570L	11090570R	5*70	10	5	70
15	11090670L	11090670R	6*70	10	6	70
16	11090770L	11090770R	7*70	10	7	70
17	11090870L	11090870R	8*70	10	8	70
18	11090970L	11090970R	9*70	10	9	70
19	11091070L	11091070R	10*70	10	10	70
20	11091170L	11091170R	11*70	10	11	70
21	11091270L	11091270R	12*70	10	12	70
22	11091370L	11091370R	13*70	10	13	70
23	11091470L	11091470R	14*70	10	14	70
24	11091570L	11091570R	15*70	10	15	70

硬质合金CNC铣刀

PCB钻头与铣刀

合金木工钻头

合金花型刀

高速钢CNC铣刀
与钻头

金刚石&合金锯片

高速钢与合金卷式
木工刀片

CNC机床配件

高性能中心钻

Carbide Tipped High Performance Centre Boring Bit

1074

序号 NO	编号 Code		关键尺寸 Size	柄径 SHK	刃长 CED	总长 OVL
	左旋 Left Rotation	右旋 Right Rotation				
1	10741657L	107457R	16*57	10	16	57
2	10741757L	107457R	17*57	10	17	57
3	10741857L	107457R	18*57	10	18	57
4	10741957L	107457R	19*57	10	19	57
5	10742057L	107457R	20*57	10	20	57
6	10742157L	107457R	21*57	10	21	57
7	10742257L	107457R	22*57	10	22	57
8	10742357L	107457R	23*57	10	23	57
9	10742457L	107457R	24*57	10	24	57
10	10742557L	107457R	25*57	10	25	57
11	10742657L	107457R	26*57	10	26	57
12	10742757L	107457R	27*57	10	27	57
13	10742857L	107457R	28*57	10	28	57
14	10742957L	107457R	29*57	10	29	57
15	10743057L	107457R	30*57	10	30	57
16	10743157L	107457R	31*57	10	31	57
17	10743257L	107457R	32*57	10	32	57
18	10743357L	107457R	33*57	10	33	57
19	10743457L	107457R	34*57	10	34	57
20	10743557L	107457R	35*57	10	35	57
21	10744057L	107457R	40*57	10	40	57
22	10741670L	107470R	16*70	10	16	70
23	10741770L	107470R	17*70	10	17	70
24	10741870L	107470R	18*70	10	18	70
25	10741970L	107470R	19*70	10	19	70
26	10742070L	107470R	20*70	10	20	70
27	10742170L	107470R	21*70	10	21	70
28	10742270L	107470R	22*70	10	22	70
29	10742370L	107470R	23*70	10	23	70
30	10742470L	107470R	24*70	10	24	70
31	10742570L	107470R	25*70	10	25	70
32	10742670L	107470R	26*70	10	26	70
33	10742770L	107470R	27*70	10	27	70
34	10742870L	107470R	28*70	10	28	70
35	10742970L	107470R	29*70	10	29	70
36	10743070L	107470R	30*70	10	30	70
37	10743170L	107470R	31*70	10	31	70
38	10743270L	107470R	32*70	10	32	70
39	10743370L	107470R	33*70	10	33	70
40	10743470L	107470R	34*70	10	34	70
41	10743570L	107470R	35*70	10	35	70
42	10744070L	107470R	40*70	10	40	70

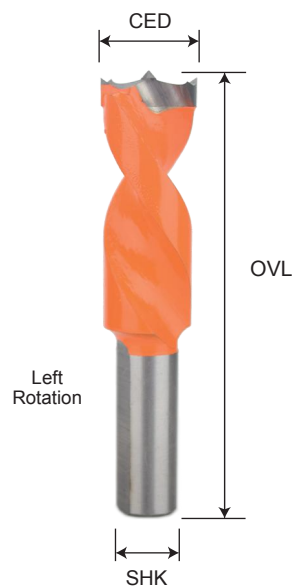

硬质合金 CNC 铣刀

PCB 钻头 铣刀

合金木工钻头

合金花型刀

与钻头
高速钢 CNC 铣刀

金刚石 & 合金锯片

木工刀片
高速钢与合金斧头式

CNC 机床配件

高性能合金通孔钻

Carbide Tipped High Performance Through-hole Boring Bit

1108

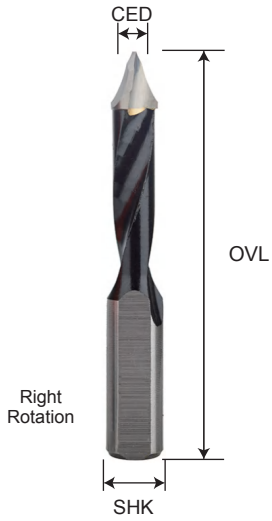

序号 No	编号 Code		关键尺寸 Size	柄径 SHK	刃径 CED	全长 OVL
	左旋 Left Rotation	右旋 Right Rotation				
1	11080557L	11080557R	5*57	10	5	57
2	11085557L	11085557R	5.5*57	10	5.5	57
3	11080657L	11080657R	6*57	10	6	57
4	11086557L	11086557R	6.5*57	10	6.5	57
5	11080757L	11080757R	7*57	10	7	57
6	11080857L	11080857R	8*57	10	8	57
7	11080957L	11080957R	9*57	10	9	57
8	11081057L	11081057R	10*57	10	10	57
9	11080570L	11080570R	5*70	10	5	70
10	11085570L	11085570R	5.5*70	10	5.5	70
11	11080670L	11080670R	6*70	10	6	70
12	11086570L	11086570R	6.5*70	10	6.5	70
13	11080770L	11080770R	7*70	10	7	70
14	11080870L	11080870R	8*70	10	8	70
15	11080970L	11080970R	9*70	10	9	70
16	11081070L	11081070R	10*70	10	10	70

硬质合金CNC铣刀

PCB钻头与铣刀

合金木工钻头

合金花型刀

高速钢CNC铣刀
与钻头

金刚石&合金锯片

高速钢与合金套式
木工刀片

CNC机床配件

刃部全合金通孔钻
TCT Through Hole Boring Bit

1111

序号 No	编号 Code		关键尺寸 Size	柄径 SHK	刃径 CED	全长 OVL
	左旋 Left Rotation	右旋 Right Rotation				
1	11110257L	11110257R	2*57	10	2	57
2	11112557L	11112557R	2.5*57	10	2.5	57
3	11110357L	11110357R	3*57	10	3	57
4	11113557L	11113557R	3.5*57	10	3.5	57
5	11110457L	11110457R	4*57	10	4	57
6	11114557L	11114557R	4.5*57	10	4.5	57
7	11110557L	11110557R	5*57	10	5	57
8	11115557L	11115557R	5.5*57	10	5.5	57
9	11110657L	11110657R	6*57	10	6	57
10	11110857L	11110857R	8*57	10	8	57
11	11110270L	11110270R	2*70	10	2	70
12	11112570L	11112570R	2.5*70	10	2.5	70
13	11110370L	11110370R	3*70	10	3	70
14	11113570L	11113570R	3.5*70	10	3.5	70
15	11110470L	11110470R	4*70	10	4	70
16	11114570L	11114570R	4.5*70	10	4.5	70
17	11110570L	11110570R	5*70	10	5	70
18	11115570L	11115570R	5.5*70	10	5.5	70
19	11110670L	11110670R	6*70	10	6	70
20	11110870L	11110870R	8*70	10	8	70

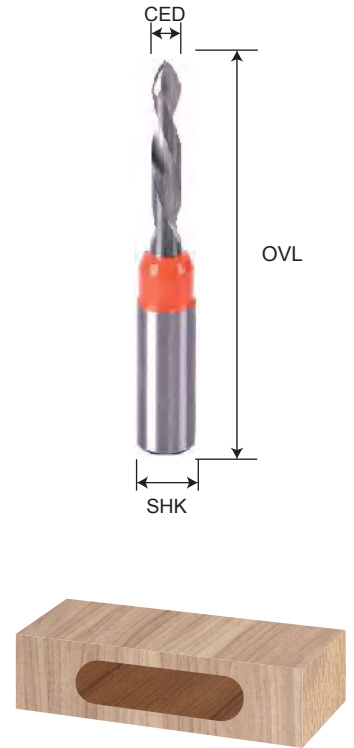

硬质合金CNC铣刀

PCB钻头合金铣刀

合金木工钻头

合金花型刀

与钻头
高速钢CNC铣刀

金刚石&合金锯片

木工刀片
高速钢与合金合金式

CNC机床配件

刃部全合金皇冠钻 TCT Type B Dowel Boring Bit

1112



序号 No	编号 Code		关键尺寸 Size	柄径 SHK	刃径 CED	全长 OVL
	左旋 Left Rotation	右旋 Right Rotation				
1	11120257L	11120257R	2*57	10	2	57
2	11120357L	11120357R	3*57	10	3	57
3	11123557L	11123557R	3.5*57	10	3.5	57
4	11120457L	11120457R	4*57	10	4	57
5	11124557L	11124557R	4.5*57	10	4.5	57
6	11120557L	11120557R	5*57	10	5	57
7	11120657L	11120657R	6*57	10	6	57
8	11120270L	11120270R	2*70	10	2	70
9	11120370L	11120370R	3*70	10	3	70
10	11123570L	11123570R	3.5*70	10	3.5	70
11	11120470L	11120470R	4*70	10	4	70
12	11124570L	11124570R	4.5*70	10	4.5	70
13	11120570L	11120570R	5*70	10	5	70
14	11120670L	11120670R	6*70	10	6	70

硬质合金CNC铣刀

PCB钻头与铣刀

合金木工钻头

合金花型刀

高速钢CNC铣刀
与钻头

金刚石&合金锯片

高速钢与合金套料式
木工刀片

CNC机床配件

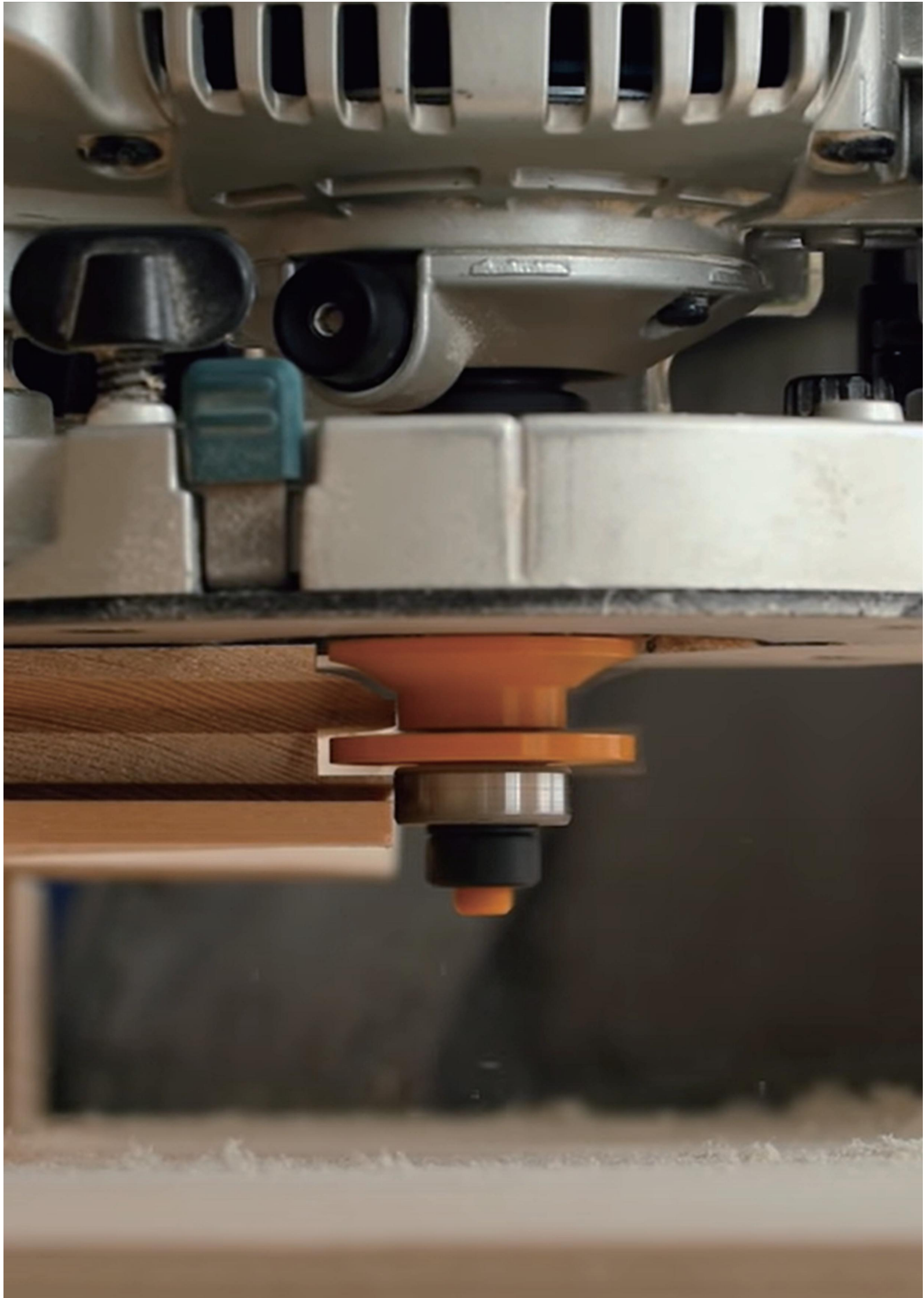

硬质合金CNC铣刀

PCB钻头与铣刀

合金木工钻头

合金成型刀

高速钢CNC铣刀
与钻头

金刚石&合金锯片

高速钢与合金套壳式
木工刀片

CNC机床配件



木工清底刀 Carbide Tipped Cleaning Bottom Bit

1025

序号	编号	关键尺寸	柄径	刃宽
NO	Order No.	Size	SHK	WIDTH
1	10250610	6*10	6	10
2	10250616	6*16	6	16
3	10250622	6*22	6	22
4	10250625	6*25	6	25
5	10250632	6*32	6	32
6	10250810	8*10	8	10
7	10250816	8*16	8	16
8	10250822	8*22	8	22
9	10250825	8*25	8	25
10	10250832	8*32	8	32
11	10251210	12.7*10	12.7	10
12	10251216	12.7*16	12.7	16
13	10251222	12.7*22	12.7	22
14	10251225	12.7*25	12.7	25
15	10251232	12.7*32	12.7	32

木工T型刀 Carbide Tipped T-Slot Surfacing Bit

1121

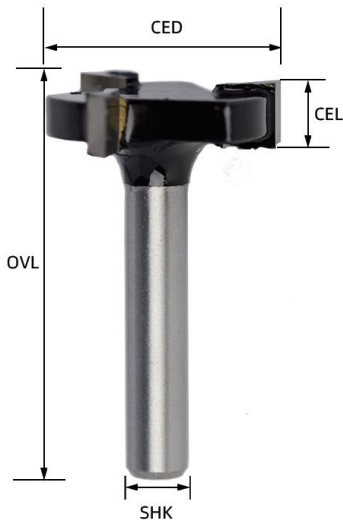

序号	编号	产品规格	柄径	刃径	刃长	总长	刃数
NO	Order No.	Size	SHK	CED	CEL	OVL	Flute
1	11211202	d25.4*6.35*D6*41L	6	25.4	6.35	41	3
2	11211022	d1*1/4*D1/4*1-19/32L	1/4"	1"	1/4"	1-19/32"	3
1	11211250	d50.8*12.7*D12*65L	12	50.8	12.7	65	4
2	11211212	d2*1/2*D1/2*2-17/32L	1/2"	2"	1/2"	2-17/32"	4

木工V槽刀

Carbide Tipped V-Groove Bit

1033

序号	编号	关键尺寸	柄径	刃宽	角度
NO	Order No.	Size	SHK	WIDTH	ANGLE
1	103361660	16*60°*6	6	16	60
2	103361690	16*90°*6	6	16	90
3	103361612	16*120°*6	6	16	120
4	103361613	16*135°*6	6	16	135
5	103361615	16*150°*6	6	16	150
6	103362260	22*60°*6	6	22	60
7	103362290	22*90°*6	6	22	90
8	103362212	22*120°*6	6	22	120
9	103362213	22*135°*6	6	22	135
10	103362215	22*150°*6	6	22	150
11	103363260	32*60°*6	6	32	60
12	103363290	32*90°*6	6	32	90
13	103363212	32*120°*6	6	32	120
14	103363213	32*135°*6	6	32	135
15	103363215	32*150°*6	6	32	150
16	103381660	16*60°*8	8	16	60
17	103381690	16*90°*8	8	16	90
18	103381612	16*120°*8	8	16	120
19	103381613	16*135°*8	8	16	135
20	103381615	16*150°*8	8	16	150
21	103382260	22*60°*8	8	22	60
22	103382290	22*90°*8	8	22	90
23	103382212	22*120°*8	8	22	120
24	103382213	22*135°*8	8	22	135
25	103382215	22*150°*8	8	22	150
26	103383260	32*60°*8	8	32	60
27	103383290	32*90°*8	8	32	90
28	103383212	32*120°*8	8	32	120
29	103383213	32*135°*8	8	32	135
30	103383215	32*150°*8	8	32	150



硬质合金CNC铣刀

PCB钻头与铣刀

合金木工钻头

合金成型刀

与钻头

高速钢CNC铣刀

金刚石合金锯片

木工刀片
高速钢与合金合金式

CNC机床配件

木工V槽刀

Carbide Tipped V-Groove Bit

1033



序号	编号	关键尺寸	柄径	刃宽	角度
NO	Order No.	Size	SHK	WIDTH	ANGLE
31	103311660	16*60°*12.7	12.7	16	60
32	103311690	16*90°*12.7	12.7	16	90
33	103311612	16*120°*12.7	12.7	16	120
34	103311613	16*135°*12.7	12.7	16	135
35	103311615	16*150°*12.7	12.7	16	150
36	103312260	22*60°*12.7	12.7	22	60
37	103312290	22*90°*12.7	12.7	22	90
38	103312212	22*120°*12.7	12.7	22	120
39	103312213	22*135°*12.7	12.7	22	135
40	103312215	22*150°*12.7	12.7	22	150
41	103312360	32*60°*12.7	12.7	32	60
42	103312390	32*90°*12.7	12.7	32	90
43	103312312	32*120°*12.7	12.7	32	120
44	103312313	32*135°*12.7	12.7	32	135
45	103312315	32*150°*12.7	12.7	32	150

硬质合金CNC铣刀

PCB钻头与铣刀

合金木工钻头

合金铣刀

高速钢CNC铣刀
与钻头

金刚石&合金锯片

高速钢与合金套式
木工刀片

CNC机床配件

木工圆底刀

Carbide Tipped Round Bottom Bit

1027

序号	编号	关键尺寸	柄径	刃宽
NO	Order No.	Size	SHK	WIDTH
1	10270610	6*12	6	12
2	10270616	6*16	6	16
3	10270622	6*22	6	22
4	10270625	6*25	6	25
5	10270632	6*32	6	32
6	10270810	8*12	8	12
7	10270816	8*16	8	16
8	10270822	8*22	8	22
9	10270825	8*25	8	25
10	10270832	8*32	8	32
11	10271210	12.7*12	12.7	12
12	10271216	12.7*16	12.7	16
13	10271222	12.7*22	12.7	22
14	10271225	12.7*25	12.7	25
15	10271232	12.7*32	12.7	32
14	10271225	12.7*25	12.7	25



木工尖嘴刀

Carbide Tipped Roundover Pointed Bit

1005

序号	编号	关键尺寸	柄径	刃径
NO	Order No.	Size	SHK	CED
1	10050612	6*12	6	12
2	10050616	6*16	6	16
3	10050622	6*22	6	22
4	10050625	6*25	6	25
5	10050632	6*32	6	32
6	10050812	8*12	8	12
7	10050816	8*16	8	16
8	10050822	8*22	8	22
9	10050825	8*25	8	25
10	10050832	8*32	8	32
11	10051212	12.7*12	12.7	12
12	10051216	12.7*16	12.7	16
13	10051222	12.7*22	12.7	22
14	10051225	12.7*25	12.7	25
15	10051232	12.7*32	12.7	32



硬质合金CNC铣刀

PCB钻头与铣刀

合金木工钻头

合金成型刀

与钻头
高速钢CNC铣刀

金刚石及合金锯片

木工刀片
高速钢与合金舍弃式

CNC机床配件



木工铝塑板专用V型刀

Carbide Tipped V-Groove Bit For Folding ACM Panels

1004

序号	编号	关键尺寸	柄径	刃径		切削高度		角度	刃数
NO	Order No.	Size	SHK	d	d1	B1	B	A	Flute
1	100419135	d19.05*135°*D12.7	12.7	19.05	1.81	3.57	7.57	135°	2
2	100412108	d12.7*108°*D12.7	12.7	12.7	2.03	3.97	7.97	108°	2
3	100412090	d12.7*90°*D12.7	12.7	12.7	2.38	5.16	9.16	90°	2

硬质合金CNC铣刀

PCB钻头与铣刀

合金木工钻头

合金花型刀

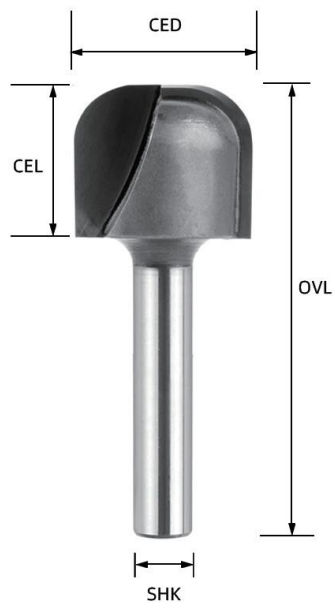

双弧圆底刀

Carbide Tipped Bowl & Tray Bit

1303

序号	编号	关键尺寸	切割直径	柄径	半径	切割长度	总长
NO	Order No.	Size	CED	SHK	R	CEL	OVL
1	130340716	7/16" *1/8" *0.25	7/16"	1/4	1/8"	5/16"	2-1/8"
2	130340304	3/4" *1/4" *0.25	3/4"	1/4	1/4"	5/8"	2-3/8"
3	130320304	3/4" *1/4" *0.5	3/4"	1/2	1/4"	5/8"	2-3/8"
4	13032114	1-1/4" *1/4" *0.5	1-1/4"	1/2	1/4"	1/2"	2-1/4"



与钻头
高速钢CNC铣刀

金刚石及合金锯片

高速钢与合金舍弃式
木工刀片

CNC机床配件

1218

单刃直刀

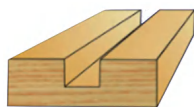

Carbide Tipped One Flute Straight Bit

1219

双刃直刀

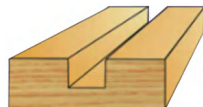

Carbide Tipped Two Flute Straight Bit

1220

公制直刀

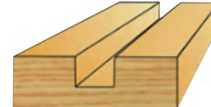
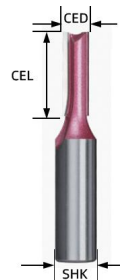

Carbide Tipped Two Flute Metric Straight Bit

1221

加长直刀

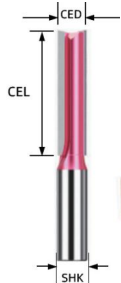

Carbide Tipped Two Flute Extended Straight Bit

1222

清底刀

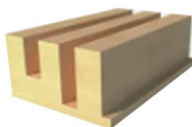
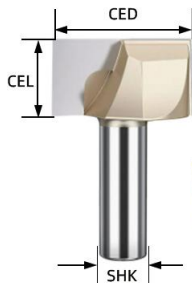

Carbide Tipped Cleaning Bottom Bit

1223

单节刀

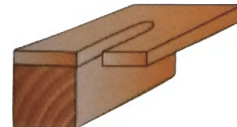
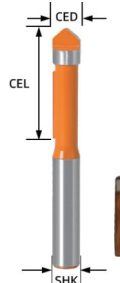

Carbide Tipped Panel Pilot Bit

1224

双节刀

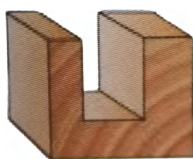
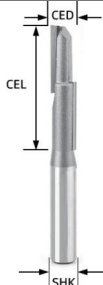

Carbide Tipped Stagger Tooth Plunge Panel Bits

1225

轴承直刀



Carbide Tipped Flush Trim Bit With Top Bearing

1226

清底直刀

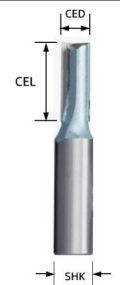

Carbide Tipped Two Flute Straight Bit With Cleaning Bottom

1227

45°斜角刀

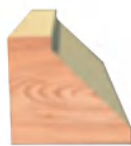

Carbide Tipped 45° Chamfer Bit

1228

加长修边刀

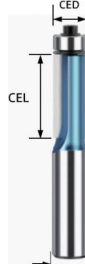

Carbide Tipped Flush Trim Bit

1229

开口雕刻刀

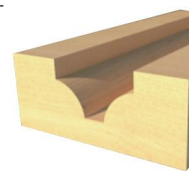
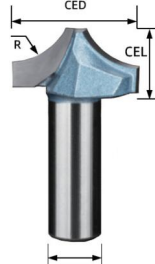

Carbide Tipped Ovolo Bit

1230 圆底刀

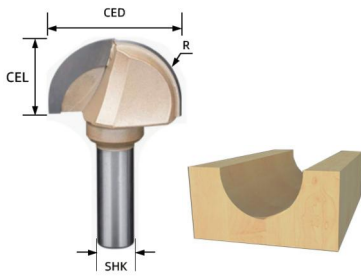

Carbide Tipped Cove Box Bit

1231 清弧刀

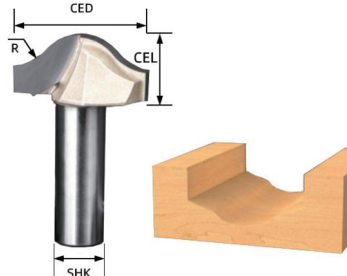

Carbide Tipped Clearing Round Bottom Bit

1232 敏仔刀

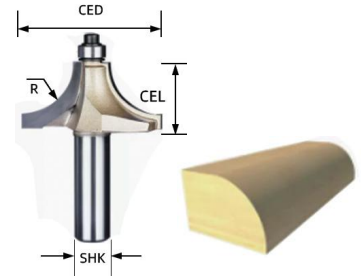

Carbide Tipped Round Over Bit

1233 弧型刀



Carbide Tipped Convex Edge Bit

1234 半圆刀

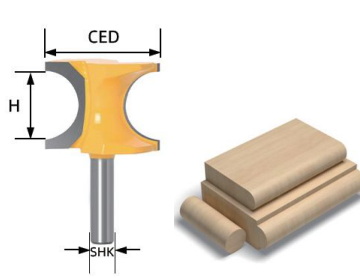

Carbide Tipped Half Round Bit

1234 户西线刀

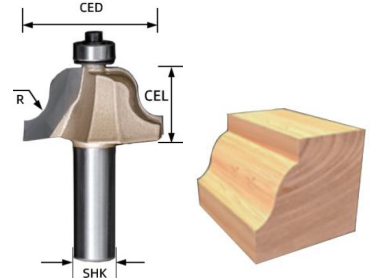

Carbide Tipped Roman Ogee Bit

1236 双R线刀

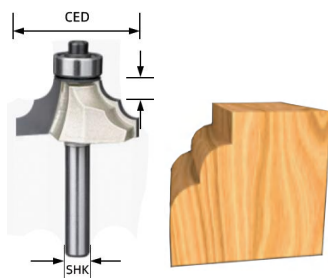

Carbide Tipped Double Roundover Edging Bit

1237 三珠饰刀

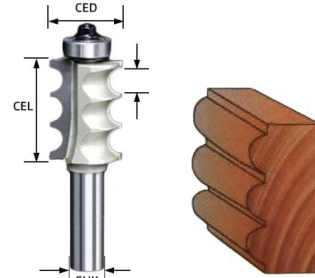

Carbide Tipped Triple Bead Molding Bit

1238 燕尾刀

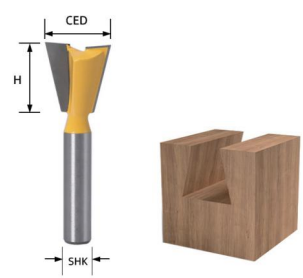

Dovetail milling cutter

1239 三齿T型榫合刀

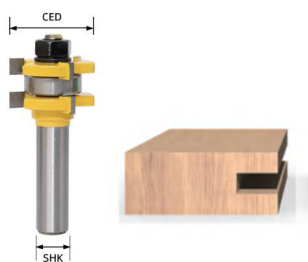

T-joint milling cutter with 3 teeth

硬质合金CNC铣刀

PCB钻头与铣刀

合金木工钻头

合金花型刀

高速钢CNC铣刀
与钻头

金刚石及合金锯片

高速钢与合金舍斧式
木工刀片

CNC机床配件

Router Bit Set

品名 Name	规格 Size
Straight Bit 直刀12.7mm	d1/2*D1/4
Flush Trim Bit with Bearing 修边刀12.7mm	d1/2*D1/4
45° Chamfer Bit With Bearing 带轴承45度斜角刀 32mm	d1.25*D1/4
Dovetail Bit 燕尾刀 12.7mm	d1/2*D1/4
Cove Box Bit With Bearing 带轴承圆底刀 R6.35mm	R1/4*D1/4
Cove Box Bit 圆底刀 6.35mm	R1/4*D1/4
Roman Ogee Bit 户西线刀 R4mm	R5/32*D1/4
90° V-Groove Bit V型刀 12.7mm	d1/2*D1/4
Corner Round Bit With Bearing 圆角刀 9.5mm	R3/8*D1/4
Straight Bit 直刀 6.35mm	d1/4*D1/4
Straight Bit 直刀 16mm	d5/8*D1/4
Corner Round Bit With Bearing 圆角刀 6.35mm	R1/4*D1/4

品名 Name	规格 Size
Cove Box Bit With Bearing 带轴承圆底刀 R6.35mm	R1/4*D1/4
Straight Bit 直刀 6.35mm	d1/4*D1/4
Corner Round Bit With Bearing 圆角刀 6.35mm	R1/4*D1/4
Straight Bit With Bearing 直刀 12.7mm	d1/2*D1/4
Straight Bit 直刀 12.7mm	d1/2*D1/4
Dovetail Bit 燕尾刀 12.7mm	d1/2*D1/4

品名 Name	规格 Size
Straight Bit 直刀3.175mm	d1/8*D1/4
Straight Bit 直刀3.175mm	R1/4*D1/4
Roman Ogee Bit 户西线刀 R4mm	R5/32*D1/4
Cove Box Bit 圆底刀 3.175mm	R1/8*D1/4
Cove Box Bit 圆底刀 3.175mm	R1/4*D1/4
90° V-Groove Bit V型刀 12.7mm	d1/2*D1/4
45° Chamfer Bit With Bearing 带轴承45度斜角刀 32mm	d1.25*D1/4
Straight Bit 直刀 6.35mm	d1/4*D1/4
Corner Round Bit With Bearing 圆角刀 6.35mm	R1/4*D1/4
Corner Round Bit With Bearing 圆角刀 9.5mm	R3/8*D1/4
Panel Pilot Bit 单节刀 6.35mm	d1/4*D1/4
Dovetail Bit 燕尾刀 12.7mm	d1/2*D1/4
Flush Trim Bit with Bearing 修边刀12.7mm	d1/2*D1/4
Straight Bit 直刀12.7mm	d1/2*D1/4
Straight Bit 直刀 16mm	d5/8*D1/4



122012PCS



122006PCS



122015PCS

硬质合金CNC铣刀

PCB钻头与铣刀

合金木工钻头

合金成型刀

与钻头
高速钢CNC铣刀

金刚石及合金锯片

木工刀片
高速钢与合金舍弃式

CNC机床配件

高速钢单刃铝型材仿型铣刀

HSS One Flute End Mill For Aluminum Profile

3099

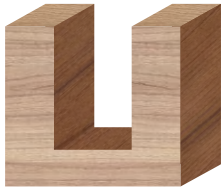
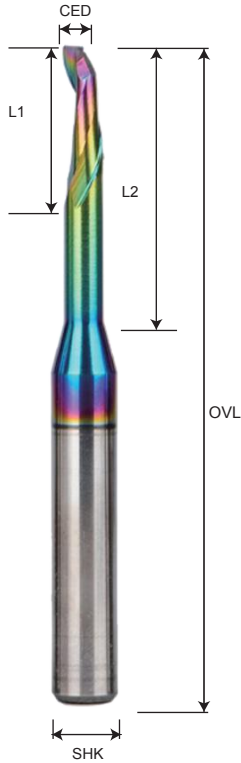

序号 NO	编号 Order No.	规格全称 Size	柄径 SHK	刃径 CED	刃长 CEL	全长 OVL
1	30993146	d3*14*D8*60L	8	3	14	60
2	30994146	d4*14*D8*60L	8	4	14	60
3	30995146	d5*14*D8*60L	8	5	14	60
4	30995168	d5*16(35)*D8*80L	8	5	16(35)	80
5	30995169	d5*16(45)*D8*90L	8	5	16(45)	90
6	309951610	d5*16(45)*D8*100L	8	5	16(45)	100
7	309951612	d5*16(65)*D8*120L	8	5	16(65)	120
8	30996146	d6*14*D8*60L	8	6	14	60
9	30996208	d6*20(35)*D8*80L	8	6	20(35)	80
10	30996209	d6*20(45)*D8*90L	8	6	20(45)	90
11	309962010	d6*20(45)*D8*100L	8	6	20(45)	100
12	309962012	d6*20(65)*D8*120L	8	6	20(65)	120
13	309973010	d7*30*D8*100L	8	7	30	100
14	30998208	d8*20*D8*80L	8	8	20	80
15	309983710	d8*30(70)*D8*100L	8	8	30(70)	100
16	309983010	d8*30*D8*100L	8	8	30	100
17	309983012	d8*30(70)*D8*120L	8	8	30(70)	120
18	309910208	d10*20*D10*80L	10	10	20	80
19	3099103010	d10*30(70)*D10*100L	10	10	30(70)	100
20	3099103012	d10*30(70)*D10*120L	10	10	30(70)	120
21	309912208	d12*20*D12*80L	12	12	20	80
22	3099123010	d12*30 (70) *D12*100L	12	12	30 (70)	100
23	3099123012	d12*30 (70) *D12*120L	12	12	30 (70)	120

硬质合金CNC铣刀

PCB钻头与铣刀

合金木工钻头

合金花型刀

高速钢CNC铣刀
与钻头

金刚石及合金锯片

高速钢与合金舍拜式
木工刀片



CNC机床配件











Quality Level

A-M 35 Material	W:6.00-6.70; Mo:4.70-5.20; Cr:3.80-4.50; V:1.70-2.00; Co:4.50-5.50
B-6542 Material	W:5.50-6.75; Mo: 4.50-5.50; Cr:3.80-4.40; V:1.75-2.20
C-4341 Material	W:3.50-4.50; Mo:2.50-3.50; Cr:3.80-4.40;V: 1.20-1.80
D-4241 Material	W:1.50-2.50; Mo:0.06-1.20; Cr:3.80-4.40; V:0.05-0.70



Production Technics

	Roll Forged
	Roll&Polished
	Fully Ground



Surface Finishing

	black Finishing
	Bright
	Black&Bright
	Tin Coated
	Rainbow Color
	Zirconium Coated
	amber
	Black&Gold

Point Angle

	118°OR 135°Split Point
	118°General Angle

Reducing Shank

	1/4 shank(6.5mm)
	3/8 shank(9.5mm)
	1/2 shank(13.0mm)

硬质合金CNC铣刀

PCB钻头与铣刀

合金木工钻头

合金花型刀

与钻头
高速钢CNC铣刀

金刚石及合金锯片

木工刀片
高速钢与合金舍弃式

CNC机床配件

高速钢全磨钻
HSS Twist Drill Bit

3035

Dia.	L2	L1
0.2	2.5	19
0.25	3	19
0.3	3	19
0.35	4	19
0.4	5	20
0.45	5	20
0.5	6	22
0.55	7	24
0.6	7	24
0.65	8	26
0.7	9	28
0.75	9	28
0.8	10	30
0.85	11	32
0.9	11	32
0.95	12	34
1	12	34
1.1	14	36
1.2	16	38
1.3	18	40
1.4	18	40
1.5	20	43
1.6	20	43
1.7	22	46
1.8	22	46
1.9	24	46
2	24	49
2.1	24	49
2.2	27	53
2.3	27	53
2.4	30	57
2.5	30	57
2.6	30	57
2.7	33	61
2.8	33	61
2.9	33	61
3	33	61
3.1	36	65
3.2	36	65
3.3	36	65
3.4	39	70
3.5	39	70
3.6	39	70
3.7	39	70
3.8	43	75
3.9	43	75
4	43	75
4.1	43	75
4.2	43	75
4.3	47	80
4.4	47	80
4.5	47	80
4.6	47	80

Dia.	L2	L1
4.7	47	80
4.8	52	86
4.9	52	86
5	52	86
5.1	52	86
5.2	52	86
5.3	52	86
5.4	57	93
5.5	57	93
5.6	57	93
5.7	57	93
5.8	57	93
5.9	57	93
6	57	93
6.1	63	101
6.2	63	101
6.3	63	101
6.4	63	101
6.5	63	101
6.6	63	101
6.7	63	101
6.8	69	109
6.9	69	109
7	69	109
7.1	69	109
7.2	69	109
7.3	69	109
7.4	69	109
7.5	69	109
7.6	75	117
7.7	75	117
7.8	75	117
7.9	75	117
8	75	117
8.1	75	117
8.2	75	117
8.3	75	117
8.4	75	117
8.5	75	117
8.6	81	125
8.7	81	125
8.8	81	125
8.9	81	125
9	81	125
9.1	81	125
9.2	81	125
9.3	81	125
9.4	81	125
9.5	81	125
9.6	87	133
9.7	87	133
9.8	87	133
9.9	87	133

Dia.	L2	L1
10	87	133
10.1	87	133
10.2	87	133
10.3	87	133
10.4	87	133
10.5	87	133
10.6	87	133
10.7	94	142
10.8	94	142
10.9	94	142
11	94	142
11.1	94	142
11.2	94	142
11.3	94	142
11.4	94	142
11.5	94	142
11.6	94	142
11.7	94	142
11.8	94	142
11.9	101	151
12	101	151
12.1	101	151
12.2	101	151
12.3	101	151
12.4	101	151
12.5	101	151
12.6	101	151
12.7	101	151
12.8	101	151
12.9	101	151
13	101	151
13.1	101	151
13.2	101	151
13.3	108	160
13.4	108	160
13.5	108	160
13.6	108	160
13.7	108	160
13.8	108	160
13.9	108	160
14	108	160
14.5	114	169
15	114	169
15.5	120	178
16	120	178
16.5	125	184
17	125	184
17.5	130	191
18	130	191
18.5	135	198
19	135	198
19.5	140	205
20	140	205

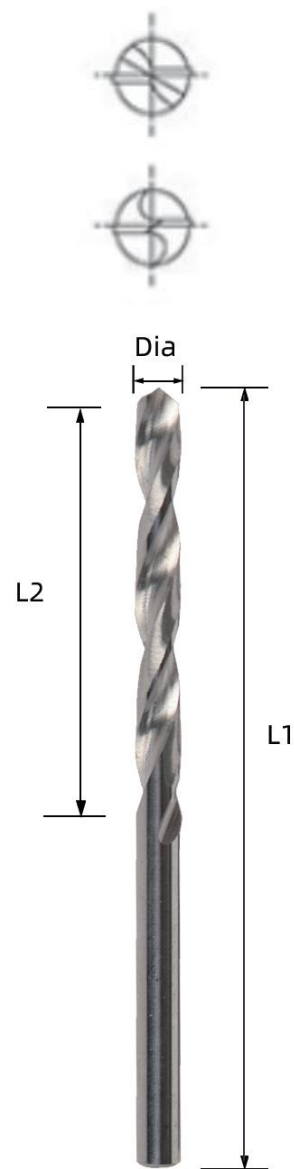

硬质合金CNC铣刀
PCB钻头与铣刀
合金木工钻头
合金花型刀
与钻头
高速钢CNC铣刀
金刚石及合金锯片
木工刀片
高速钢与合金舍斧式
CNC机床配件

HSS Twist Drill Bit Set

序号 NO	编号 Order No.	关键尺寸 Size	刃径 CED
1	520115PCS	15PCS	1.5/2/2.5/3/3.2/3.5/4/4.5/5/5.5/6/6.5/7/7.5/8
2	520113PCS	13PCS	2/2.5/3/3.5/4/4.5/5/5.5/6/6.5/7/7.5/8
3	520119PCS	19PCS	1/1.5/2/2.5/3/3.5/4/4.5/5/5.5/6/6.5/7/7.5/8/8.5/9/9.5/10
4	520125PCS	25PCS	1/1.5/2/2.5/3/3.5/4/4.5/5/5.5/6/6.5/7/7.5/8/8.5/9/9.5/10/10.5/11/11.5/12/12.5/13

Packaging Diagram



PVC bag



Blister card



Paper bag



Plastic box



Portable box



Plastic box



Iron box



Wooden box

硬质合金CNC铣刀

PCB钻头与铣刀

合金木工钻头

合金花型刀

高速钢CNC铣刀
与钻头

金刚石及合金锯片

高速钢与合金舍弃式
木工刀片

CNC机床配件

高速钢单刃倒角钻

HSS One Flute Chamfer Countersink Drill Bit

30791

序号	编号	关键尺寸	刃径	柄径	角度	总长	刃数
NO	Order No.	Size	CED	SHK	ANGLE	OVL	Z
1	307910405	4.5*90	4.5	4	90	40	1
2	307910603	6.3*90	6.3	5	90	45	1
3	307910803	8.3*90	8.3	6	90	50	1
4	307911004	10.4*90	10.4	6	90	50	1
5	307911204	12.4*90	12.4	8	90	56	1
6	3079114	14*90	14	10	90	60	1
7	307911605	16.5*90	16.5	10	90	60	1
8	30791180	18*90	18	10	90	63	1
9	307912005	20.5*90	20.5	10	90	63	1
10	3079125	25*90	25	10	90	67	1
11	3079130	30*90	30	12	90	71	1
12	3079135	35*90	35	12	90	82	1
13	3079140	40*90	40	12	90	92	1
14	3079145	45*90	45	12	90	92	1
15	3079150	50*90	50	12	90	100	1
16	3079160	60*90	60	12	90	120	1
17	307916PCS	20.5*/16.5/12.4/10.4/8.3/6.3			90		1

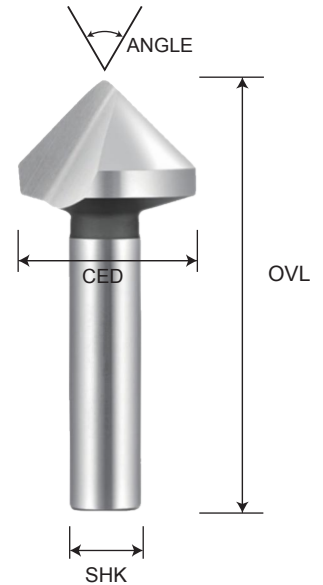

高速钢三刃倒角钻

HSS Three Flutes Chamfer Countersink Drill Bit

30792

序号	编号	关键尺寸	刃径	柄径	角度	总长	刃数
NO	Order No.	Size	CED	SHK	ANGLE	OVL	Z
1	307920405	4.5*90	4.5	4	90	40	3
2	307920603	6.3*90	6.3	5	90	45	3
3	307920803	8.3*90	8.3	6	90	50	3
4	307921004	10.4*90	10.4	6	90	50	3
5	307921204	12.4*90	12.4	8	90	56	3
6	3079214	14*90	14	10	90	60	3
7	307921605	16.5*90	16.5	10	90	60	3
8	30792180	18*90	18	10	90	63	3
9	307922005	20.5*90	20.5	10	90	63	3
10	3079225	25*90	25	10	90	67	3
11	3079230	30*90	30	12	90	71	3
12	3079235	35*90	35	12	90	82	3
13	3079240	40*90	40	12	90	92	3
14	3079245	45*90	45	12	90	92	3
15	3079250	50*90	50	12	90	100	3
16	3079260	60*90	60	12	90	120	3
17	307926PCS	20.5*/16.5/12.4/10.4/8.3/6.3			90		3

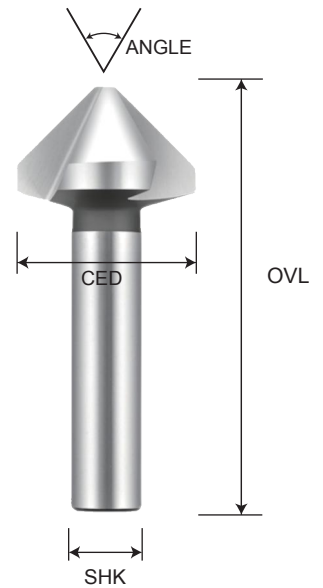

硬质合金CNC铣刀

PCB钻头与铣刀

合金木工钻头

合金铣刀

与钻头
高速钢CNC铣刀

金刚石及合金锯片

木工刀片
高速钢与合金斧头

CNC机床配件

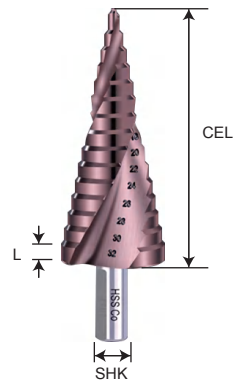
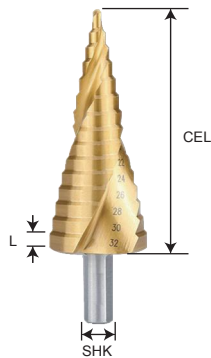
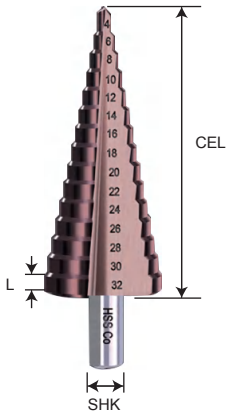
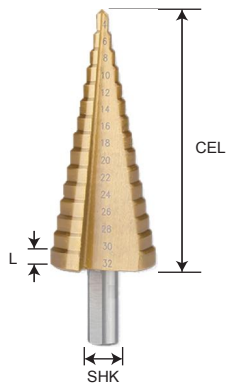

高速钢直槽宝塔钻 HSS Straight Step Drill Bit **3050**

序号 NO	编号 Order No.	关键尺寸 Size	刃长 CEL	柄径 SHK	总长 OVL
1	305030412	4-12	7	6	42
2	305030420	4-20	4.5	8	52
3	305030432	4-32	4	10	78

序号 NO	编号 Order No.	关键尺寸 Size	刃长 CEL	柄径 SHK	总长 OVL
1	305040412	4-12	7	6	42
2	305040420	4-20	4.5	8	52
3	305040432	4-32	4	10	78

高速钢螺旋槽宝塔钻 HSS Spiral Step Drill Bit **3051**

序号 NO	编号 Order No.	关键尺寸 Size	刃长 CEL	柄径 SHK	总长 OVL
1	305130412	4-12	7	6	42
2	305130420	4-20	4.5	8	52
3	305130432	4-32	4	10	78

序号 NO	编号 Order No.	关键尺寸 Size	刃长 CEL	柄径 SHK	总长 OVL
1	305140412	4-12	7	6	42
2	305140420	4-20	4.5	8	52
3	305140432	4-32	4	10	78

硬质合金CNC铣刀
 PCB钻头与铣刀
 合金木工钻头
 合金花型刀
 高速钢CNC铣刀
 与钻头
 金刚石及合金锯片
 高速钢与合金舍弃式
 木工刀片
 CNC机床配件

高速钢棒眼刀

HSS Tenon Mortise Bit

3090

序号	编号	关键尺寸	柄径	刃径	总长	刃数
NO	Order No.	Size	SHK	CED	OVL	Z
1	30906100	6*4	1/2	6	100	4
2	30908100	8*4	1/2	8	100	4
3	30909100	9*4	1/2	9	100	4
4	309010100	10*4	1/2	10	100	4
5	309012100	12*4	1/2	12	100	4
6	309014100	14*4	1/2	14	100	4
7	309015100	15*4	1/2	15	100	4
8	309016100	16*4	1/2	16	100	4

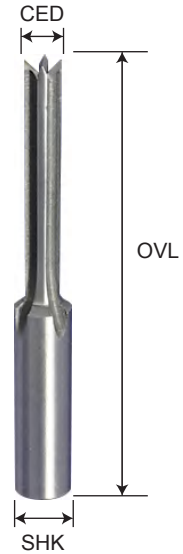

高速钢水槽铣刀

HSS Flume End Mill

3107

序号	编号	关键尺寸	刃径	刃长	柄径	总长
NO	Order No.	Size	CED	CEL	SHK	OVL
1	31070450	4*50	4	25	6	50
2	31070550	5*50	5	25	6	50
3	31070475	4*75	4	25	6	75
4	31070575	5*75	5	25	6	75

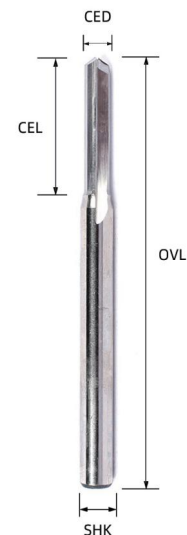

高速钢外牙钻

HSS External Drill Bit

3091

序号	编号	关键尺寸	螺纹	刃径	刃长	总长
NO	Order No.	Size	TAP	CED	CEL	OVL
1	30910553	5*53	M8	5	53	100
2	30910653	6*53	M8	6	53	100
3	30910753	7*53	M8	7	53	100
4	30910853	8*53	M8	8	53	100
5	30910953	9*53	M8	9	53	100
6	30911053	10*53	M8	10	53	100
7	30911253	12*53	M8	12	53	100

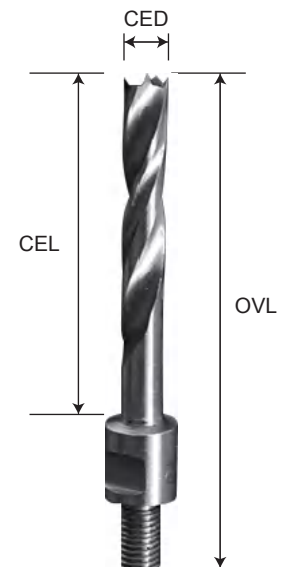

硬质合金CNC铣刀

PCB钻头与铣刀

合金木工钻头

合金花型刀

与钻头
高速钢CNC铣刀

金刚石及合金锯片

木工刀片
高速钢与合金舍弃式

CNC机床配件

硬质合金CNC铣刀

PCB钻头与铣刀

合金木工钻头

合金花型刀

高速钢CNC铣刀
与钻头

金刚石及合金锯片

高速钢与合金舍弃式
木工刀片

CNC机床配件



高速钢沙拉钻 HSS Salad Drill Bit

3182

序号	编号	关键尺寸	柄径	刃径	钻套直径	总长
NO	Order No.	Size	SHK	CED	D	OVL
1	31820612	10*6*12	10	6	12	100
2	31820512	10*5*12	10	5	12	100
3	31820510	10*5*10	10	5	10	100
4	31820410	10*4*10	10	4	10	100
5	31820509	10*5*9	10	5	9	100
6	31820409	10*4*9	10	4	9	100
7	31820508	10*5*8	10	5	8	100
8	31820408	10*4*8	10	4	8	100
9	31820308	10*3*8	10	3	8	100

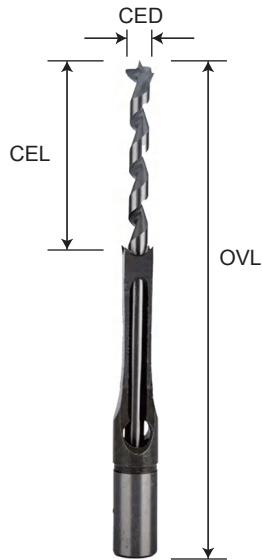

高速钢方孔钻 HSS Square Hole Drill Bit

3010

序号	编号	关键尺寸	方孔大小	开槽深度	总长
NO	Order No.	Size	CED	CEL	OVL
1	30100645	6*45	6	45	175
2	30106445	6.4*45	6.4	45	175
3	30100860	8*60	8	60	195
4	30109860	9.5*60	9.5	60	195
5	30101060	10*60	10	60	195
6	30101160	11*60	11	60	195
7	301012560	12.5*60	12.5	60	195
8	301012765	12.7*65	12.7	65	195
9	30101475	14*75	14	75	220
10	30101575	15*75	15	75	220
11	30101675	16*75	16	75	220
12	30101875	18*75	18	75	220
13	30101975	19*75	19	75	220
14	30102075	20*75	20	75	220
15	30102275	22*75	22	75	220
16	30102570	25*70	25	70	220
17	30103070	30*70	30	70	230



金刚石锯片

Diamond Circular Saw Blade

601

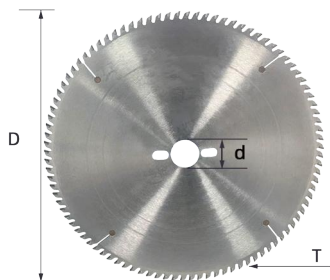

序号 NO	编号 Order No.	关键尺寸 Size	直径 D	切宽/板厚 H	孔径 d	齿数 T
1	6011202024	120*3.0-4.0*20/22*24T划线	120	3.0-4.0	20/22	24T划线
2	6011002012	100*2.8-3.6*20*12+12T划线	100	2.8-3.6	20	12+12T划线
3	6011002212	100*2.8-3.6*22*12+12T划线	100	2.8-3.6	22	12+12T划线
4	6011202012	120*2.8-3.6*20*12+12T划线	120	2.8-3.6	20	12+12T划线
5	6011202212	120*2.8-3.6*22*12+12T划线	120	2.8-3.6	22	12+12T划线
6	6011603343	160*3.3-4.3*30*36T划线	160	3.3-4.3	30	36T划线
7	6011604353	160*4.3-5.3*30*36T划线	160	4.3-5.3	30	36T划线
8	6011803343	180*3.3-4.3*30*36T划线	180	3.3-4.3	30	36T划线
9	6011804353	180*4.3-5.3*30*36T划线	180	4.3-5.3	30	36T划线
10	6013003260	300*3.2*30*60T	300	3.2	30	60T
11	6013003272	300*3.2*30*72T	300	3.2	30	72T
12	6013003284	300*3.2*30*84T	300	3.2	30	84T
13	6013003296	300*3.2*30*96T	300	3.2	30	96T
14	6013503572	350*3.5*30*72T	350	3.5	30	72T
15	6013503584	350*3.5*30*84T	350	3.5	30	84T
16	6013503896	350*3.5*30*96T	350	3.5	30	96T
17	60135072	350*4.4*30/60/75*72T	350	4.4	30/60/75	72T
18	60135084	350*4.4*30/60/75*84T	350	4.4	30/60/75	84T
19	60136072	360*4.4*30/60/75*72T	360	4.4	30/60/75	72T
20	60136084	360*4.4*30/60/75*84T	360	4.4	30/60/75	84T
21	60138072	380*4.4*60/75*72T	380	4.4	60/75	72T
22	60138084	380*4.4*60/75*84T	380	4.4	60/75	84T
23	6013806084	380*4.8*60*84T	380	4.8	60	84T
24	60140084	400*4.4*60/75*84T	400	4.4	60/75	84T
25	60145084	450*4.8*60/75*84T	450	4.8	60/75	84T
26	60173072	730*7*40*72T	730	7	40	72T

合金裁板锯锯片

TCT Circular Saw Blade For Cutting-off

602

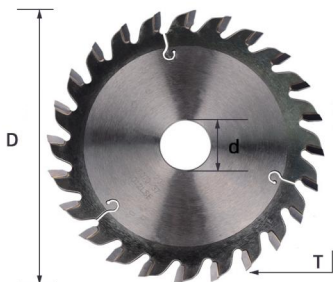

序号 NO	编号 Order No.	关键尺寸 Size	直径 D	切宽/板厚 H	孔径 d	齿数 T
1	60225460	254*3.2/2.2*30*60T	254	3.2/2.2	30	60T
2	60230060	300*3.2/2.2*30*60T	300	3.2/2.2	30	60T
3	60230072	254*3.2/2.2*30*60T	300	3.2/2.2	30	72T
4	60230096	300*3.2/2.2*30*60T	300	3.2/2.2	30	96T
5	60230080	254*3.2/2.2*30*60T	300	3.2/2.2	30	80T
6	60235072	300*3.2/2.2*30*60T	350	3.5/2.5	30	72T
7	60235084	254*3.2/2.2*30*60T	350	3.5/2.5	30	84T
8	60235096	300*3.2/2.2*30*60T	350	3.5/2.5	30	96T

硬质合金CNC铣刀

PCB钻头与铣刀

合金木工钻头

合金花型刀

与钻头
高速钢CNC铣刀

金刚石及合金锯片

高速钢与合金舍弃式
木工刀片

CNC机床配件

合金通用型锯片

TCT General Circular Saw Blade

603

序号 NO	编号 Order No.	关键尺寸 Size	直径 D	切宽/板厚 H	孔径 d	齿数 T
1	60318040	180*2.5/1.8*25.4/30/35*40T	180	2.5/1.8	25.4/30/35	40T
2	60318060	180*2.5/1.8*25.4/30/35*60T	180	2.5/1.8	25.4/30/35	60T
3	60318080	180*2.5/1.8*25.4/30/35*80T	180	2.5/1.8	25.4/30/35	80T
4	60320340	203*2.8/2.0*25.4/30/35*40T	203	2.8/2.0	25.4/30/35	40T
5	60320360	203*2.8/2.0*25.4/30/35*60T	203	2.8/2.0	25.4/30/35	60T
6	60320380	203*2.8/2.0*25.4/30/35*80T	203	2.8/2.0	25.4/30/35	80T
7	60323040	230*2.8/2.0*25.4/30*40T	230	2.8/2.0	25.4/30	40T
8	60323060	230*2.8/2.0*25.4/30*60T	230	2.8/2.0	25.4/30	60T
9	60323080	230*2.8/2.0*25.4/30*80T	230	2.8/2.0	25.4/30	80T
10	6032303040	230*3.0/2.2*25.4/30*40T	230	3.0/2.2	25.4/30	40T
11	6032303060	230*3.0/2.2*25.4/30*60T	230	3.0/2.2	25.4/30	60T
12	60325440	254*3.0/2.2*25.4/30*40T	254	3.0/2.2	25.4/30	40T
13	60325460	254*3.0/2.2*25.4/30*60T	254	3.0/2.2	25.4/30	60T
14	60325480	254*3.0/2.2*25.4/30*80T	254	3.0/2.2	25.4/30	80T
15	603254100	254*3.0/2.2*25.4/30*100T	254	3.0/2.2	25.4/30	100T
16	603254120	254*3.0/2.2*25.4/30*120T	254	3.0/2.2	25.4/30	120T
17	60330540	305*3.0/2.2*25.4/30*40T	305	3.0/2.2	25.4/30	40T
18	60330560	305*3.0/2.2*25.4/30*60T	305	3.0/2.2	25.4/30	60T
19	60330580	305*3.0/2.2*25.4/30*80T	305	3.0/2.2	25.4/30	80T
20	603305100	305*3.0/2.2*25.4/30*100T	305	3.0/2.2	25.4/30	100T
21	603305120	305*3.0/2.2*25.4/30*120T	305	3.0/2.2	25.4/30	120T
22	60335560	355*3.0/2.2*25.4/30*60T	355	3.0/2.2	25.4/30	60T
23	60335580	355*3.0/2.2*25.4/30*80T	355	3.0/2.2	25.4/30	80T
24	603355100	355*3.0/2.2*25.4/30*100T	355	3.0/2.2	25.4/30	100T
25	603355120	355*3.0/2.2*25.4/30*120T	355	3.0/2.2	25.4/30	120T
26	60340560	405*3.5/2.5*30*60T	405	3.5/2.5	30	60T
27	60340580	405*3.5/2.5*25.4/30*80T	405	3.5/2.5	25.4/30	80T

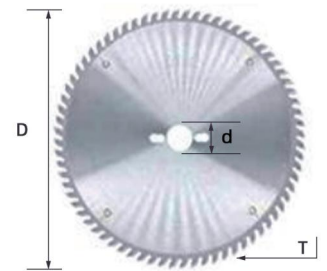

硬质合金CNC铣刀

PCB钻头与铣刀

合金木工钻头

合金成型刀

与钻头
高速钢CNC铣刀

金刚石&合金锯片

木工刀片
高速钢与合金舍弃式

CNC机床配件

合金划线专用锯片

TCT Circular Saw Blade For Scoring

604

序号 NO	编号 Order No.	关键尺寸 Size	直径 D	切宽/板厚 H	孔径 d	齿数 T
1	60412024	120*3.0-4.0*20/22*24T划线	120	3.0-4.0	20/22	24T划线
2	6041002012	100*2.8-3.6*20*12+12T划线	100	2.8-3.6	20	12+12T划线
3	6041002212	100*2.8-3.6*22*12+12T划线	100	2.8-3.6	22	12+12T划线
4	6041202012	120*2.8-3.6*20*12+12T划线	120	2.8-3.6	20	12+12T划线
5	6041202212	120*2.8-3.6*22*12+12T划线	120	2.8-3.6	22	12+12T划线
6	6041603336	160*3.3-4.3*30*36T划线	160	3.3-4.3	30	36T划线
7	6041604336	160*4.3-5.3*30*36T划线	160	4.3-5.3	30	36T划线
8	6041803336	180*3.3-4.3*30*36T划线	180	3.3-4.3	30	36T划线
9	6041804336	180*4.3-5.3*30*36T划线	180	4.3-5.3	30	36T划线

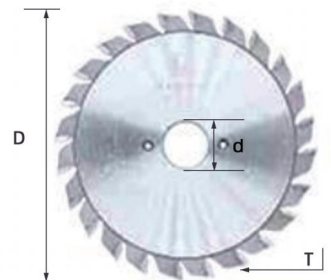

铝合金专用合金锯片

TCT Circular Saw Blade For Aluminum

605

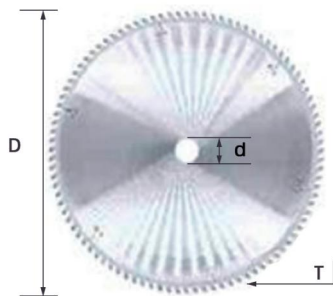

序号 NO	编号 Order No.	关键尺寸 Size	直径 D	切宽/板厚 H	孔径 d	齿数 T
1	605250100	250*3.0/2.4*25.4/30*100T	250	3.0/2.4	25.4/30	100T
2	605250120	250*3.0/2.4*25.4/30*120T	250	3.0/2.4	25.4/30	120T
3	605300100	300*3.0/2.4*25.4/30*100T	300	3.0/2.4	25.4/30	100T
4	605300120	300*3.0/2.4*25.4/30*120T	300	3.0/2.4	25.4/30	120T
5	605350100	350*3.2/2.6*25.4/30*100T	350	3.2/2.6	25.4/30	100T
6	605350120	350*3.2/2.6*25.4/30*120T	350	3.2/2.6	25.4/30	120T
7	605400120	400*3.5/2.9*25.4/30*120T	400	3.5/2.9	25.4/30	120T
8	605450100	450*4.0/3.4*30/32*100T	450	4.0/3.4	30/32	100T
9	605450120	450*4.0/3.4*30/32*120T	450	4.0/3.4	30/32	120T
10	605500100	500*4.4/3.8*30/32*100T	500	4.4/3.8	30/32	100T
11	605500120	500*4.4/3.8*30/32*120T	500	4.4/3.8	30/32	120T

合金电子开料锯锯片

TCT Circular Saw Blade For Ripping

606

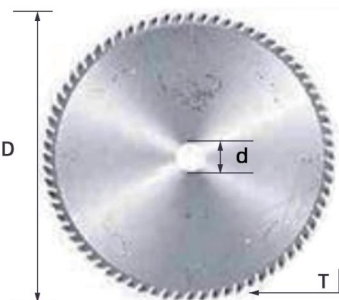

序号 NO	编号 Order No.	关键尺寸 Size	直径 D	切宽/板厚 H	孔径 d	齿数 T
1	60630060	300*4.0/3.0*30*60T	300	4.0/3.0	30	60T
2	60630072	300*4.0/3.0*30*72T	300	4.0/3.0	30	72T
3	60630096	300*4.0/3.0*30*96T	300	4.0/3.0	30	96T
4	6063004496	300*4.4/3.2*30/80*96T	300	4.4/3.2	30/80	96T
5	60635072	350*4.0/3.0*30/60*72T	350	4.0/3.0	30/60	72T
6	6063502572	350*4.4/3.2*25.4/30*72T	350	4.4/3.2	25.4/30	72T
7	6063506072	350*4.4/3.2*60/75*72T	350	4.4/3.2	60/75	72T
8	60635084	350*4.0/3.0*30/60*84T	350	4.0/3.0	30/60	84T
9	6063502584	350*4.4/3.2*25.4/30*84T	350	4.4/3.2	25.4/30	84T
10	6063506084	350*4.4/3.2*60/75/80*84T	350	4.4/3.2	60/75/80	84T
11	6063502596	350*4.4/3.2*25.4/30*96T	350	4.4/3.2	25.4/30	96T
12	6063506096	350*4.4/3.2*60/75*96T	350	4.4/3.2	60/75	96T
13	6063806072	380*4.4/3.2*60/75*72T	380	4.4/3.2	60/75	72T
14	60638084	380*4.4/3.2*60*84T	380	4.4/3.2	60	84T
15	60638096	380*4.4/3.2*60*96T	380	4.4/3.2	60	96T
16	60638072	380*4.8/3.6*60*72T	380	4.8/3.6	60	72T
17	6063803684	380*4.4/3.6*60*84T	380	4.4/3.6	60	84T
18	6063806096	380*4.8/3.6*60*96T	380	4.8/3.6	60	96T
19	6064003072	400*4.4/3.2*30/60*72T	400	4.4/3.2	30/60	72T
20	6064007572	400*4.4/3.2*75/80*72T	400	4.4/3.2	75/80	72T

硬质合金CNC铣刀

PCB钻头与铣刀

合金木工钻头

合金花型刀

高速钢CNC铣刀
与钻头

金刚石及合金锯片

高速钢与合金舍弃式
木工刀片

CNC机床配件

合金电子开料锯锯片

TCT Circular Saw Blade For Ripping

606

序号 NO	编号 Order No.	关键尺寸 Size	直径 D	切宽/板厚 H	孔径 d	齿数 T
21	6064003084	400*4.4/3.2*30/60*84T	400	4.4/3.2	30/60	84T
22	6064007584	400*4.4/3.2*75/80*84T	400	4.4/3.2	75/80	84T
23	6064006096	400*4.4/3.2*60/75*96T	400	4.4/3.2	60/75	96T
24	6064307596	430*4.4/3.2*75*96T	430	4.4/3.2	75	96T
25	6064503072	450*4.4/3.2*30*72T	450	4.4/3.2	30	72T
26	6064506072	450*4.4/3.2*60/80*72T	450	4.4/3.2	60/80	72T
27	6064506084	450*4.4/3.4*60/75/80*84T	450	4.4/3.4	60/75/80	84T
28	6064504872	450*4.8/3.6*60/80*72T	450	4.8/3.6	60/80	72T
29	6064504884	450*4.8/3.6*60/80*84T	450	4.8/3.6	60/80	84T
30	6064504896	450*4.8/3.6*60/80*96T	450	4.8/3.6	60/80	96T

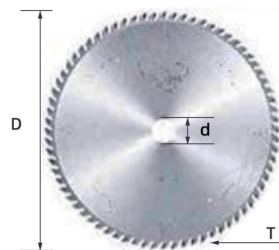

硬质合金CNC铣刀

PCB钻头台铣刀

合金木工钻头

合金花型刀

与钻头
高速钢CNC铣刀

金刚石&合金锯片

木工刀片
高速钢与合金舍弃式

CNC机床配件

合金封边锯锯片

TCT Circular Saw Blade For Edge-Banding

607

序号 NO	编号 Order No.	关键尺寸 Size	直径 D	切宽/板厚 H	孔径 d	齿数 T
1	6073024	100*3*22*24T	100	3.0	22	24T
2	6073224	100*3.2*22*24T	100	3.2	22	24T
3	607104324	104*3*22*24T	104	3.0	22	24T
4	607104330	104*3*22*30T	104	3.0	22	30T
5	6071043224	104*3.2*22*24T	104	3.2	22	24T
6	607102330	104*3.2*22*30T	104	3.2	22	30T

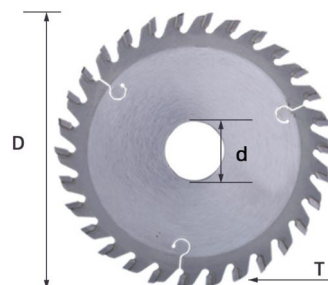

合金实木横裁锯锯片

TCT Circular Saw Blade For Cross-Cutting

608

序号 NO	编号 Order No.	关键尺寸 Size	直径 D	切宽/板厚 H	孔径 d	齿数 T
1	608254100	254*3.0/2.2*25.4/30*100T	254	3.0/2.2	25.4/30	100T
2	608254120	254*3.0/2.2*25.4/30*120T	254	3.0/2.2	25.4/30	120T
3	6082543210	254*3.0/2.2*25.4/30*100T	254	3.2/2.2	25.4/30	100T
4	6082543212	254*3.0/2.2*25.4/30*100T	254	3.2/2.2	25.4/30	120T
5	608330010	254*3.0/2.2*25.4/30*100T	300	3.2/2.5	25.4/30	100T
6	60830012	254*3.0/2.2*25.4/30*100T	300	3.2/2.5	25.4/30	120T
7	60835010	254*3.0/2.2*25.4/30*100T	350	3.5/2.5	25.4/30	100T
8	60835012	254*3.0/2.2*25.4/30*100T	350	3.5/2.5	25.4/30	120T

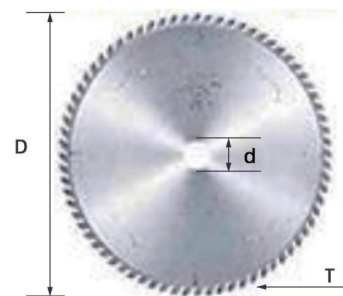

硬质合金CNC铣刀

PCB钻头与铣刀

合金木工钻头

合金花型刀

高速钢CNC铣刀
与钻头

金刚石及合金锯片

高速钢与合金舍弃式
木工刀片

CNC机床配件

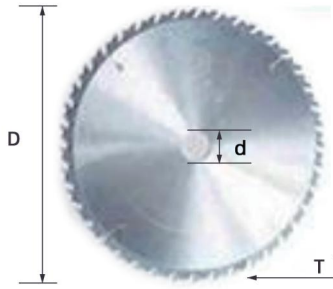

合金纵切用锯片 TCT Circular Saw Blade For Ripping

609

序号 NO	编号 Order No.	关键尺寸 Size	直径 D	切宽/板厚 H	孔径 d	齿数 T
1	60923040	230*3.2/2.2*25.4/30*40T	230	3.2/2.2	25.4/30	40T
2	60925040	250*3.2/2.2*25.4/30*40T	250	3.2/2.2	25.4/30	40T
3	60925060	250*3.2/2.2*25.4/30*60T	250	3.2/2.2	25.4/30	60T
4	60930048	300*3.2/2.2*25.4/30*48T	300	3.2/2.2	25.4/30	48T
5	60930060	300*3.2/2.2*25.4/30*60T	300	3.2/2.2	25.4/30	60T
6	60935054	350*3.5/2.5*25.4/30*54T	350	3.5/2.5	25.4/30	54T
7	60935060	350*3.5/2.5*25.4/30*60T	350	3.5/2.5	25.4/30	60T
8	60940060	400*3.5/2.5*25.4/30*60T	400	3.5/2.5	25.4/30	60T
9	60930028	300*3.2/2.2*25.4/30*28T	300	3.2/2.2	25.4/30	28T
10	60930036	300*3.2/2.2*25.4/30*36T	300	3.2/2.2	25.4/30	36T
11	60935032	350*3.2/2.2*25.4/30*32T	350	3.2/2.2	25.4/30	32T

合金修边锯片 TCT Circular Saw Blade For Flush Trimming

610

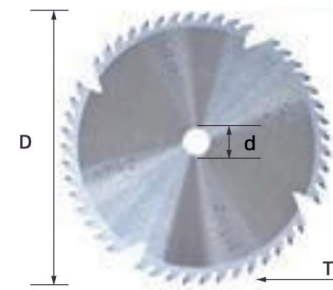

序号 NO	编号 Order No.	关键尺寸 Size	直径 D	切宽/板厚 H	孔径 d	齿数 T
1	61030048	300*3.2/2.2*30*48T	300	3.2/2.2	30	48T
2	61030548	305*4.0/3*25.4/30*48T	305	4.0/3	25.4/30	48T
3	61030560	305*4.0/3*50.8*60T	305	4.0/3	50.8	60T
4	61035070	350*5.0/3.6*50.8*70T	350	5.0/3.6	50.8	70T
5	61040070	400*5.0/3.6*50.8*70T	400	5.0/3.6	50.8	70T

合金胶合板专用锯片 TCT Circular Saw Blade For Plywoos

611

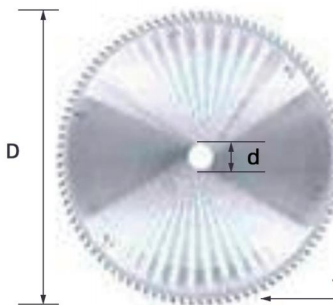

序号 NO	编号 Order No.	关键尺寸 Size	直径 D	切宽/板厚 H	孔径 d	齿数 T
1	61124010	254*3.2/2.2*25.4*100T	254	3.2/2.2	25.4	100T
2	61125412	254*3.2/2.2*25.4*120T	254	3.2/2.2	25.4	120T
3	61130010	300*3.2/2.2*25.4/30*100T	300	3.2/2.2	25.4/30	100T
4	611300610	300*3.2/2.2*60*100T	300	3.2/2.2	60	100T
5	61130012	300*3.2/2.2*25.4/30*120T	300	3.2/2.2	25.4/30	120T
6	611300612	300*3.2/2.2*60*120T	300	3.2/2.2	60	120T
7	61130510	305*3.2/2.2*25.4*100T	305	3.2/2.2	25.4	100T
8	61130512	305*3.2/2.2*25.4*120T	305	3.2/2.2	25.4	120T
9	611305612	305*3.2/2.2*65*120T	305	3.2/2.2	65	120T

舍弃式木工T型刀

Inserted Surfacing Bit With Replacement Insert

1202

序号	编号	直径	刀片尺寸	柄径	总长	刃数
NO	Order No.	CED	Insert Size	SHK	OVL	Flute
1	120235635	35	10.5*10.5*2.2	6.35	65	3
2	12023508	35	10.5*10.5*2.2	8	65	3
3	12025012	50	12*12*2.2	12	65	3/4
4	120250127	50	12*12*2.2	12.7	65	3/4
5	12126012	60	12*12*2.2	12	65	3/4
6	121260127	60	12*12*2.2	12.7	65	3/4



舍弃式木工V型刀

Inserted V-Groove Bit With Replacement Insert

2007

序号	编号	关键尺寸	刃径	角度	刀片尺寸	柄径	总长	刃数
NO	Order No.	Size	CED	Angle	Insert Size	SHK	OVL	Flute
1	20071040	47/64*40°*1/2	47/64	40°	27*9*1.5	1/2	2.5	1
2	20071045	47/64*45°*1/2	47/64	45°	27*9*1.5	1/2	2.5	1
3	20071046	0.875*50°*1/2	1	50°	27*9*1.5	1/2	2.5	1
4	20071142	1.5*90°*1/2	2	90°	30*12*1.5	1/2	2.5	2
5	20071104	2*120°*12	2	120°	29.8*12*1.5	12	2.5	2



硬质合金CNC铣刀

PCB钻头与铣刀

合金木工钻头

合金花型刀

与钻头
高速钢CNC铣刀

金刚石及合金锯片

木工刀片
高速钢与合金舍弃式

CNC机床配件

高速钢木工刨刀片 HSS Planer Blade

3186



序号 NO	编号 Order No.	关键尺寸 Size	厚度 W	高度 T	总长 L
1	318632590	90*25*3	3	25	90
2	3186325100	100*25*3	3	25	100
3	3186325120	120*25*3	3	25	120
4	3186325150	150*25*3	3	25	150
5	3186325160	160*25*3	3	25	160
6	3186325200	200*25*3	3	25	200
7	3186325210	210*25*3	3	25	210
8	3186325250	250*25*3	3	25	250
9	3186325260	260*25*3	3	25	260
10	3186325300	300*25*3	3	25	300
11	3186325310	310*25*3	3	25	310
12	3186325500	500*25*3	3	25	500
13	318633070	70*30*3	3	30	70
14	318633080	80*30*3	3	30	80
15	318633090	90*30*3	3	30	90
16	3186330100	100*30*3	3	30	100
17	3186330120	120*30*3	3	30	120
18	3186330150	150*30*3	3	30	150
19	3186330200	200*30*3	3	30	200
20	3186330210	210*30*3	3	30	210
21	3186330250	250*30*3	3	30	250
22	3186330260	260*30*3	3	30	260
23	3186330300	300*30*3	3	30	300
24	3186330310	310*30*3	3	30	310
25	3186330350	350*30*3	3	30	350
26	3186330400	400*30*3	3	30	400
27	3186330450	450*30*3	3	30	450
28	3186330500	500*30*3	3	30	500
29	3186330510	510*30*3	3	30	510
30	3186330600	600*30*3	3	30	600
31	3186330610	610*30*3	3	30	610
32	3186330630	630*30*3	3	30	630
33	3186335300	300*35*3	3	35	300
34	3186335350	350*35*3	3	35	350
35	3186335400	400*35*3	3	35	400
36	3186335450	450*35*3	3	35	450
37	3186335500	500*35*3	3	35	500
38	3186335600	600*35*3	3	35	600
39	3186335630	630*35*3	3	35	630
40	3186335640	640*35*3	3	35	640
41	3186440300	300*40*4	4	40	300
42	3186440640	640*40*4	4	40	640

硬质合金CNC铣刀
PCB钻头与铣刀
合金木工钻头
合金花型刀
与钻头
高速钢CNC铣刀
金刚石及合金锯片
高速钢与合金舍套式木工刀片
CNC机床配件

高速钢木工刨刀片

HSS Planer Blade

3186

序号 NO	编号 Order No.	关键尺寸 Size	厚度 W	高度 T	总长 L
43	3186440350	350*40*4	4	40	350
44	3186440400	400*40*4	4	40	400
45	3186440450	450*40*4	4	40	450
46	3186440500	500*40*4	4	40	500
47	3186440600	600*40*4	4	40	600
48	3186440630	630*40*4	4	40	630



合金木工刨刀片

TCT Planer Blade

3187

序号 NO	编号 Order No.	关键尺寸 Size	厚度 W	高度 T	合金宽度 T1	总长 L
1	318732580	80*25*3*1.0	3	25	1.00	80
2	318732590	90*25*3*1.0	3	25	1.0	90
3	3187325100	100*25*3*1.0	3	25	1.0	100
4	3187325120	120*25*3*1.0	3	25	1.0	120
5	3187325200	200*25*3*1.0	3	25	1.0	200
6	3187325260	260*25*3*1.0	3	25	1.0	260
7	3187325300	300*25*3*1.0	3	25	1.0	300
8	3187325400	400*25*3*1.0	3	25	1.0	400
9	3187330100	100*30*3*1.0	3	30	1.0	100
10	31873302001	200*30*3*1.0	3	30	1.0	200
11	3187330210	210*30*3*1.0	3	30	1.0	210
12	3187330250	250*30*3*1.0	3	30	1.0	250
13	31873303001	300*30*3*1.0	3	30	1.0	300
14	3187330310	310*30*3*1.0	3	30	1.0	310
15	3187330320	320*30*3*1.0	3	30	1.0	320
16	3187330350	350*30*3*1.0	3	30	1.0	350
17	3187330400	400*30*3*1.0	3	30	1.0	400
18	3187330410	410*30*3*1.0	3	30	1.0	410
19	3187330500	500*30*3*1.0	3	30	1.0	500
20	31873306001	600*30*3*1.0	3	30	1.0	600
21	3187330630	630*30*3*1.0	3	30	1.0	630
22	3187530630	630*30*5*1.0	5	30	1.0	630
23	3187330200	200*30*3*1.5	3	30	1.5	200
24	3187330300	300*30*3*1.5	3	30	1.5	300
25	3187330600	600*30*3*1.5	3	30	1.5	600
26	3187335300	300*35*3*1.5	3	35	1.5	300
27	3187335400	400*35*3*1.5	3	35	1.5	400
28	31873302002	200*30*3*2.0	3	30	2.0	200
29	31873303002	200*30*3*2.0	3	30	2.0	300
30	3187430400	200*30*3*2.0	4	30	2.0	400
31	31873353002	200*30*3*2.0	3	35	2.0	300
32	3187440300	200*30*3*2.0	4	40	2.0	300
33	3187440400	200*30*3*2.0	4	40	2.0	400



硬质合金CNC铣刀

PCB钻头与铣刀

合金木工钻头

合金花型刀

与钻头
高速钢CNC铣刀

金刚石及合金锯片

木工刀片
高速钢与合金套式

CNC机床配件

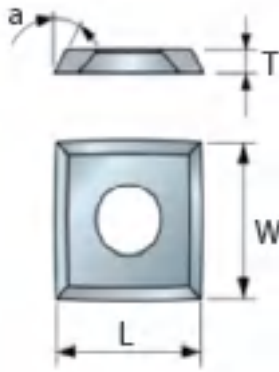

合金木工舍弃式刀片

Solid Carbide Replacement Insert Knife

5025

序号	编号	关键尺寸	长度	宽度	厚度	角度
NO	Order No.	Size	L	W	T	A
1	50251430	14*14*2*30°	14	14	2	30°
2	50251435	14*14*2*35°	14	14	2	35°
3	50251530	15*15*2.5*30°	15	15	2.5	30°
4	50251535	15*15*2.5*35°	15	15	2.5	35°

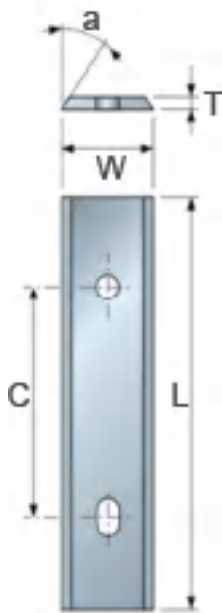

合金木工舍弃式刀片

Solid Carbide Replacement Insert Knife

5026

序号	编号	关键尺寸	长度	宽度	厚度	角度
NO	Order No.	Size	L	W	T	A
1	50263035	30*12*1.5**35°	30	12	1.5	35°
2	50264035	40*12*1.5**35°	40	12	1.5	35°
3	50265035	50*12*1.5**35°	50	12	1.5	35°
4	50266035	60*12*1.5**35°	60	12	1.5	35°

合金木工封边机刀片

Solid Carbide Radius Profile Replacement Insert Knife

5027

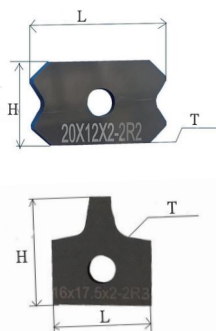

序号	编号	关键尺寸	长度	宽度	厚度	角度
NO	Order No.	Size	L	W	T	A
1	50272021	20*12*2*2R1	20	12	2	1
2	502720215	20*12*2*2R1.5	20	12	2	1.5
3	50272022	20*12*2R2	20	12	2	2
4	50272023	20*12*2R3	20	12	2	3
5	50271621	16*17.5*2*2R1	16	17.5	2	1
6	502716215	16*17.5*2*2R1.5	16	17.5	2	1.5
7	50271622	16*17.5*2*2R2	16	17.5	2	2
8	50271623	16*17.5*2*2R3	16	17.5	2	3

硬质合金CNC铣刀

PCB钻头与铣刀

合金木工钻头

合金花型刀

高速钢CNC铣刀
与钻头

金刚石&合金锯片

高速钢与合金舍弃式
木工刀片

CNC机床配件



ER夹头
ER Collet

5011



序号	编号	关键尺寸	类别	尺寸	夹紧范围
NO	Order No.	Size	Type	Size	Range
1	50110802	ER8-2	ER8	2	1.5-2.0
2	50110825	ER8-2.5	ER8	2.5	2.0-2.5
3	50110803	ER8-3	ER8	3	2.5-3.0
4	50110835	ER8-3.5	ER8	3.5	3.0-3.5
5	50110804	ER8-4	ER8	4	3.5-4.0
6	50110845	ER8-4.5	ER8	4.5	4.0-4.5
7	50110805	ER8-5	ER8	5	4.5-5.0
8	50111101	ER11-1	ER11	1	0.5-1.0
9	50111115	ER11-1.5	ER11	1.5	1.0-1.5
10	50111102	ER11-2	ER11	2	1.5-2.0
11	50111125	ER11-2.5	ER11	2.5	2.0-2.5
12	50111103	ER11-3	ER11	3	2.5-3.0
13	50111135	ER11-3.5	ER11	3.5	3.0-3.5
14	50111104	ER11-4	ER11	4	3.5-4.0
15	50111145	ER11-4.5	ER11	4.5	4.0-4.5
16	50111105	ER11-5	ER11	5	4.5-5.0
17	50111155	ER11-5.5	ER11	5.5	5.0-5.5
18	50111106	ER11-6	ER11	6	5.5-6.0
19	50111165	ER11-6.5	ER11	6.5	6.0-6.5
20	50111107	ER11-7	ER11	7	6.5-7.0
21	50111601	ER16-1	ER16	1	0.5-1.0
22	50111602	ER16-2	ER16	2	1.0-2.0
23	50111603	ER16-3	ER16	3	2.0-3.0
24	50111604	ER16-4	ER16	4	3.0-4.0
25	50111605	ER16-5	ER16	5	4.0-5.0
26	50111606	ER16-6	ER16	6	5.0-6.0
27	50111607	ER16-7	ER16	7	6.0-7.0
28	50111608	ER16-8	ER16	8	7.0-8.0
29	50111609	ER16-9	ER16	9	8.0-9.0
30	50111610	ER16-10	ER16	10	9.0-10.0
31	50112001	ER20-1	ER20	1	0.5-1.0
32	50112002	ER20-2	ER20	2	1.0-2.0
33	50112003	ER20-3	ER20	3	2.0-3.0
34	50112004	ER20-4	ER20	4	3.0-4.0
35	50112005	ER20-5	ER20	5	4.0-5.0
36	50112006	ER20-6	ER20	6	5.0-6.0
37	50112007	ER20-7	ER20	7	6.0-7.0
38	50112008	ER20-8	ER20	8	7.0-8.0
39	50112009	ER20-9	ER20	9	8.0-9.0
40	50112010	ER20-10	ER20	10	9.0-10.0
41	50112011	ER20-11	ER20	11	10.0-11.0
42	50112012	ER20-12	ER20	12	11.0-12.0
43	50112013	ER20-13	ER20	13	12.0-13.0
44	50112501	ER25-1	ER25	1	0.5-1.0
45	501125105	ER25-1.5	ER25	1.5	1-1.5
46	50112502	ER25-2	ER25	2	1.5-2.0

硬质合金CNC铣刀

PCB钻头与铣刀

合金木工钻头

合金花型刀

高速钢CNC铣刀
与钻头

金刚石&合金锯片

高速钢与合金舍弃式
木工刀片

CNC机床配件

ER夹头
ER Collet

5011

序号	编号	关键尺寸	类别	尺寸	夹紧范围
NO	Order No.	Size	Type	Size	Range
47	50112525	ER25-2.5	ER25	2.5	2-2.5
48	50112503	ER25-3	ER25	3	2.5-3.0
49	501125108	ER25-1/8"	ER25	1/8"	3-3.175
50	50112504	ER25-4	ER25	4	3.0-4.0
51	50112505	ER25-5	ER25	5	4.0-5.0
52	50112506	ER25-6	ER25	6	5.0-6.0
53	50112507	ER25-7	ER25	7	6.0-7.0
54	50112508	ER25-8	ER25	8	7.0-8.0
55	50112509	ER25-9	ER25	9	8.0-9.0
56	50112510	ER25-10	ER25	10	9.0-10.0
57	50112511	ER25-11	ER25	11	10.0-11.0
58	50112512	ER25-12	ER25	12	11.0-12.0
59	50112513	ER25-13	ER25	13	12.0-13.0
60	50112514	ER25-14	ER25	14	13.0-14.0
61	50112515	ER25-15	ER25	15	14.0-15.0
62	50112516	ER25-16	ER25	16	15.0-16.0
63	50112517	ER25-17	ER25	17	16.0-17.0
64	50112518	ER25-18	ER25	18	17.0-18.0
65	50112519	ER25-19	ER25	19	18.0-19.0
66	50112520	ER25-20	ER25	20	19.0-20.0
67	50113202	ER32-2	ER32	2	1-2
68	50113203	ER32-3	ER32	3	2-3
69	50113218	ER32-1/8"	ER32	1/8"	3-3.175
70	50113204	ER32-4	ER32	4	3-4
71	50113205	ER32-5	ER32	5	4-5
72	50113206	ER32-6	ER32	6	5-6
73	50113207	ER32-7	ER32	7	6-7
74	50113208	ER32-8	ER32	8	7-8
75	50113209	ER32-9	ER32	9	8-9
76	50113210	ER32-10	ER32	10	9-10
77	50113211	ER32-11	ER32	11	10-11
78	50113212	ER32-12	ER32	12	11-12
79	50113213	ER32-13	ER32	13	12-13
80	50113214	ER32-14	ER32	14	13-14
81	50113215	ER32-15	ER32	15	14-15
82	50113216	ER32-16	ER32	16	15-16
83	50113217	ER32-17	ER32	17	16-17
84	50113218	ER32-18	ER32	18	17-18
85	50113219	ER32-19	ER32	19	18-19
86	50113220	ER32-20	ER32	20	19-20
87	5011118PCS	ER11-8PCS		3.175/1/2/3/4/5/6/7	
88	50111610PCS	ER16-10PCS		1/2/3/4/5/6/7/8/9/10	
89	50112013PCS	ER20-13PCS		1/2/3/4/5/6/7/8/9/10/11/12/13	
90	50112515PCS	ER25-15PCS		2/3/4/5/6/7/8/9/10/11/12/13/14/15/16	
91	50113218PCS	ER32-18PCS		3/4/5/6/7/8/9/10/11/12/13/14/15/16/17/18/19/20	
92	50114024PCS	ER40-24PCS		3/4/5/6/7/8/9/10/11/12/13/14/15/16/17/18/19/20/21/22/23/24/25/26	



硬质合金CNC铣刀

PCB钻头与铣刀

合金木工钻头

合金花型刀

与钻头
高速钢CNC铣刀

金刚石&合金锯片

木工刀片
高速钢与合金舍斧式

CNC机床配件

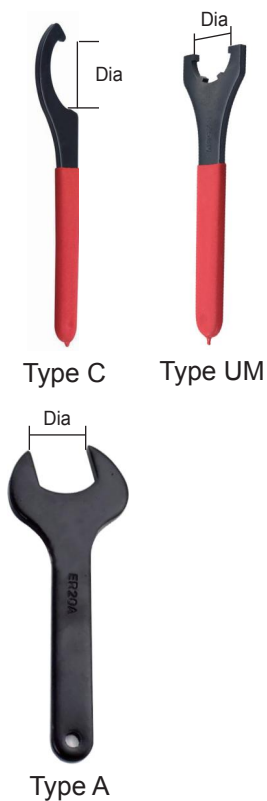

ER扳手 ER Wrench

5021

序号 NO	编号 Order No.	关键尺寸 Size	直径 Dia	总长 OVL	型号 Type
1	5021125	ER25C-25	25	190	C
2	5021132	ER32C-32	30	190	C
3	5021140	ER40C-40	45	210	C
4	5021216	ER16UM-16	28	210	UM
5	5021220	ER20UM-20	30	210	UM
6	5021225	ER25UM-25	37	210	UM
7	5021232	ER32UM-32	45	250	UM
8	5021240	ER40UM-40	58	290	UM
9	5021250	ER50UM-50	72	350	UM
10	5021308	ER8A-8	12	110	A
11	5021311	ER11A-11	17	110	A
12	5021316	ER16A-16	25	120	A
13	5021320	ER20A-20	30	130	A

ER螺母 ER Nut

5014



序号 NO	编号 Order No.	关键尺寸 Size	高度 H	外径 D	牙距 Thread
1	501411119	ER11A	19	11.3	M14*0.75P
2	501411628	ER16A	28	17.5	M22*15P
3	501412034	ER20A	34	19	M25*1.5P
4	501410812	ER8A	12	10.8	M10*0.75P
5	501420812	ER8M	12	10.8	M10*0.75P
6	501421116	ER11M	16	12	M13*1.75P
7	501421622	ER16M	22	18	M19*1.0P
8	501422028	ER20M	28	19	M24*1.0P
9	501422535	ER25A	35	20	M30*1.0P
10	501432542	ER25UM	42	20	M32*1.5P
11	501433250	ER32UM	50	22.5	M40*1.5P
12	501434063	ER40UM	63	25.5	M50*1.5P

吸尘螺母

Dust Chip Extraction Nut

5080

序号	编号	关键尺寸	外径	内径	高
NO	Order No.	Size	D	d	Height
1	508020	ER20	63	23	40
2	508025	ER25	63	30	36
3	508032	ER32	78	38	40
4	508040	ER40	83	48	40
5	5080257	OZ25	78	45	42

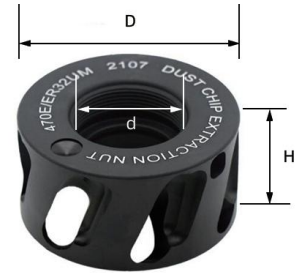

高性能ER滚珠螺母

High Performance Ball Bearing ER Nut

5009

序号	编号	关键尺寸	外径	高度	牙距
NO	Order No.	Size	D	H	Pitch
1	50092342	ER25GM	42	21.5	M32*P1.5
2	50093210	ER32GM	50	24.0	M40*P1.5

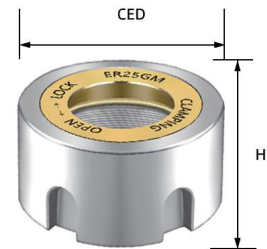

卡爪

CNC Tool Fork

5102

序号	编号	关键尺寸	关键尺寸						总长
			d3	d1	d2	L2	L3	L1	
NO	Order No.	Size							
1	51023627	ISO20	36	27	33	38	29	19	83
2	51027144	ISO30	71	44	49.5	60	40	39.5	102
3	51024132	ISO25	41	32	37	38	29	19	83
4	51027139	NBT30	71	39	44.5	60	40	39.5	102
5	51024550	BT40	45.5	50		64.5	38.5	28.5	82
6	51025263	HSK63F	52.5	63		84.5	39	39	99.5

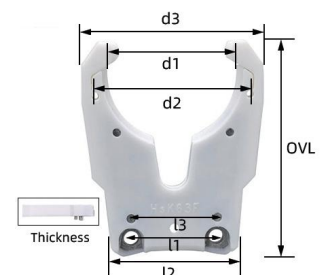

硬质合金CNC铣刀

PCB钻头与铣刀

合金木工钻头

合金铣型刀

与钻头
高速钢CNC铣刀

金刚石&合金锯片

木工刀片
高速钢与合金舍斧式

CNC机床配件

变径套 Collet Adapter

5012



序号 NO	编号 Order No.	关键尺寸 Size	内径 d	外径 D
1	50120603	6-3	3	6
2	50120631	6-3.175	3.175	6
3	50120604	6-4	4	6
4	50126331	6.35-3.175	3.175	6.35
5	50126304	6.35-4	4	6.35
6	501212731	12.7-3.175	3.175	12.7
7	501212704	12.7-4	4	12.7
8	501212706	12.7-6	6	12.7
9	501212763	12.7-6.35	6.35	12.7
10	501212708	12.7-8	8	12.7
11	50121210	12.7-10	10	12.7

排钻钻套 Quick Change Adapter

5007



序号 NO	编号 Order No.	关键尺寸 Size	类型 Type	外径 D	高度 H	内径 d
1	50074010	20*14*40	Cross	20	40	14
2	50074001	20*14*40	Straight	20	40	14
3	50074510	20*14*45	Cross	20	45	14
4	50074501	20*14*45	Straight	20	45	14

HSK-63F 刀柄 HSK-63F CNC Holder

5089



序号 NO	编号 Order No.	型号 Model	D	L	L1	夹紧范围 Range
1	50891670	HSK63F-ER16-70L	28	70	44	1.0-10.0
2	508916100	HSK63F-ER16-100L	28	100	74	1.0-10.0
3	508920100	HSK63F-ER20-100L	34	100	74	1.0-13.0
4	508925100	HSK63F-ER25-100L	42	100	74	1.0-16.0
5	50893273	HSK63F-ER32-73L	50	73	47	3.0-20.0
6	50894075	HSK63F-ER40-75L	63	76	47	4.0-26.0

硬质合金CNC铣刀

PCB钻头与铣刀

合金木工钻头

合金花型刀

高速钢CNC铣刀
与钻头

金刚石&合金锯片

高速钢与合金舍弃式
木工刀片

CNC机床配件

BT30 & BT40 刀柄

BT30 & BT40 CNC Holder

5088

序号	编号	关键尺寸	L	L1	D1	夹持范围
NO	Order No.	Size				Range
1	5088301660	BT30-ER16-70L	60	40	28	1--10
2	50883016100	BT30-ER16-100L	100	80	28	1--10
3	5088302060	BT30-ER20-70L	60	40	34	1--13
4	50883020100	BT30-ER20-100L	100	80	34	1--13
5	5088302560	BT30-ER25-70L	60	40	41.5	1--16
6	50883025100	BT30-ER25-100L	100	80	41.5	1--16
7	5088303260	BT30-ER32-70L	60	40	49.5	1--20
8	50883032100	BT30-ER32-100L	100	80	49.5	1--20
9	5088401670	BT40-ER16-70L	70	45	28	1--10
10	50884016100	BT40-ER16-100L	100	75	28	1--10
11	5088402070	BT40-ER20-70L	70	45	34	1--13
12	50884020100	BT40-ER20-100L	100	75	34	1--13
13	5088402570	BT40-ER25-70L	70	45	41.5	1--16
14	50884025100	BT40-ER25-100L	100	75	41.5	1--16
15	5088403270	BT40-ER32-70L	70	45	49.5	1--20
16	50884032100	BT40-ER32-100L	100	75	49.5	1--20
17	5088404080	BT40-ER40-80L	70	45	63	1--25
18	50884040100	BT40-ER40-100L	100	75	63	1--25



ISO30刀柄

ISO30 CNC Holder

5132

序号	编号	关键尺寸	D	D1	D2	L	Range
NO	Order No.	Size					Range
1	51321660	ISO30-ER16-060	28	50	32	60	1—10
2	51322045	ISO30-ER20-045	34	50	32	45	1—13
3	51322060	ISO30-ER20-060	34	50	32	60	1—13
4	51322545	ISO30-ER25-045	42	50	32	45	1—13
5	51322560	ISO30-ER25-060	42	50	32	60	1—16
6	51323245	ISO30-ER32-045	50	50	32	45	1—16
7	51323260	ISO30-ER32-060	50	50	32	60	1—20
8	513216100	ISO30-ER16-100	28	50	32	100	1—20
9	513220100	ISO30-ER20-100	34	50	32	100	1—13



硬质合金CNC铣刀

PCB钻头与铣刀

合金木工钻头

合金成型刀

与钻头
高速钢CNC铣刀

金刚石及合金锯片

木工刀片
高速钢与合金舍弃式

CNC机床配件

WEIX[®]
TERY[®]



Address: Dagang Guanghua Industrial Park
Zhenjiang New District, Jiangsu Province, China
TEL: (+86)0511-83373758 FAX: (+86)0511-83372830
WhatsApp: (+86)18306105100
E-mail: info@weixtool.com

For more information, please contact us to
provide you with more accurate products.

